

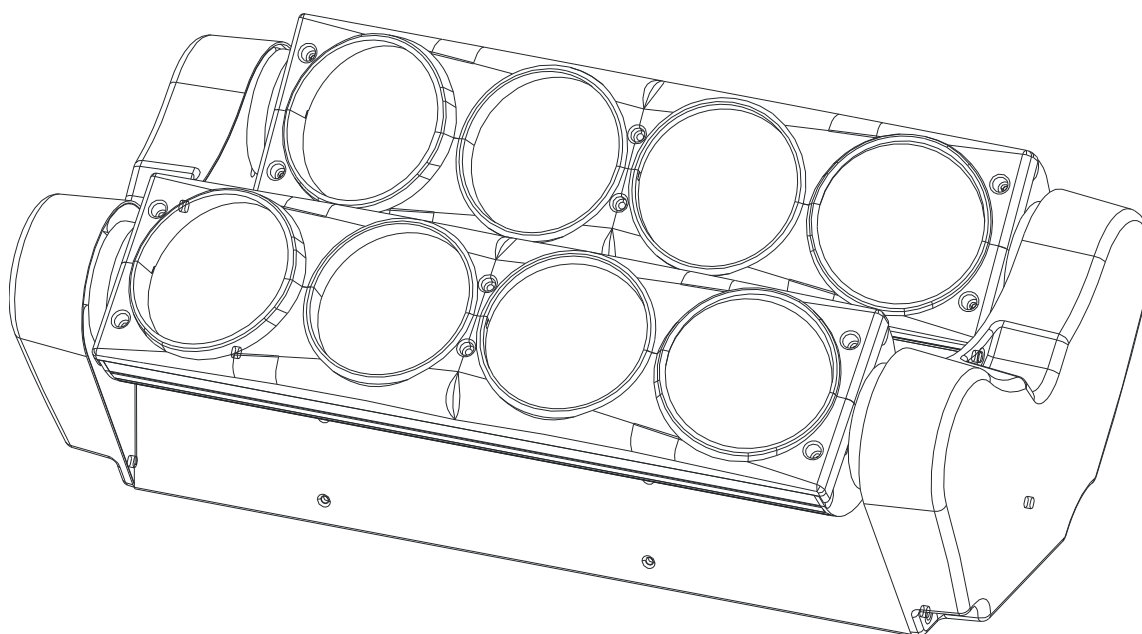

BUTTERFLY

Quad



User Manual

Please read the instruction carefully before use

CONTENTS

1. Safety Instructions.....	2
2. Technical Specifications.....	3
3. How To Set The Unit.....	4
3.1 Control Panel.....	4
3.2 Main Function	5
4. How to Control the Unit.....	10
4.1 Master/Slave Built In Pre-program Function.....	11
4.2 Easy CA-8 Controller.....	11
4.3 DMX Controller.....	12
5. DMX512 Configuration.....	13
6. DMX Connection	16
7. Troubleshooting	17
8. Fixture Cleaning.....	18

1. Safety Instructions



WARNING

Please read the instructions carefully which includes important information about the installation, operation and maintenance.

Please keep this User Guide for future consultation. If you sell the unit to another user, be sure that they also receive this instruction booklet.

- Unpack and check carefully there is no transportation damage before using the unit.
- Before operating, ensure that the voltage and frequency of power supply match the power requirements of the unit.
- It's important to ground the yellow/green conductor to earth in order to avoid electric shock.
- The unit is for indoor use only. Use only in a dry location.
- The unit must be installed in a location with adequate ventilation, at least 50cm from adjacent surfaces. Be sure that no ventilation slots are blocked.
- Disconnect main power before replacement or servicing.
- Make sure there are no flammable materials close to the unit while operating as it is fire hazard.
- Use safety cable when installing this unit. DO NOT handle the unit by taking its head only, but always by taking its base.
- Maximum ambient temperature is T_a : 40 degrees C. DO NOT operate it where the temperature is higher than this.
- Unit surface temperature may reach up to 65 degrees C. DO NOT touch the housing with bare-hands during its operation. Turn off the power and allow about 15 minutes for the unit to cool down before replacing or serving.
- In the event of a serious operating problem, stop using the unit immediately. Never try to repair the unit by yourself. Repairs carried out by unskilled people can lead to damage or malfunction. Please contact the nearest authorized technical assistance center. Always use the same type spare parts.
- DO NOT touch any cables during operation as high voltage may cause electric shock.

Warning:

- To prevent or reduce the risk of electrical shock or fire, do not expose the unit to rain or moisture.
- The housing and lenses must be replaced if they are visibly damaged.

Installation:

The fixture should be mounted via its Omega Quick Release Clamp bracket. Always ensure that the unit is firmly fixed to avoid vibration and slipping while operating and make sure that the structure to which you are attaching the unit is secure and is able to support a weight of 10 times of the fixtures weight. Always use a safety cable that can hold 12 times of the weight of the fixture when installing.

The equipment must be installed by professionals and it must be installed in a place where is out of the reach of people and no one can pass by or under it.

2. Technical Specifications

- 2 x rotating LED bars, each with 4 pixel controlled 8W LEDs
- 3 Operation Modes: DMX, Master/Slave, and Sound Activation.
- DMX Channel modes: 1,6,12, 36 channels
- Optional easy controller CA-8 for instant lighting show.
- Great built-in programs in master/slave operation triggered by music.
- Electronic dimming and various strobe effects.
- Ideal for pubs, clubs, bars, parties, Mobile DJs and more.

- **Input Voltage:** AC 100 ~ 240V, 50/60Hz
- **Power Consumption:** 66.5W
- **Power Cable Daisy Chains:** 10 Fixtures Max. (230V, 50Hz)
6 Fixtures Max. (120V, 60Hz)
- **LED:** 8 x 8W Quad-color LEDs

- **Weight:** 5.5kgs
- **Dimension:** 395 x 234 x 180mm

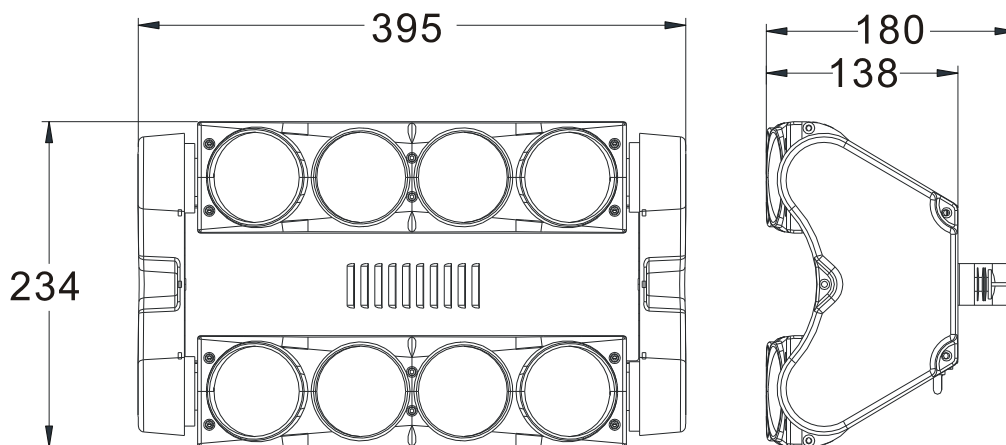

3. How To Set The Unit

3.1 Control Panel

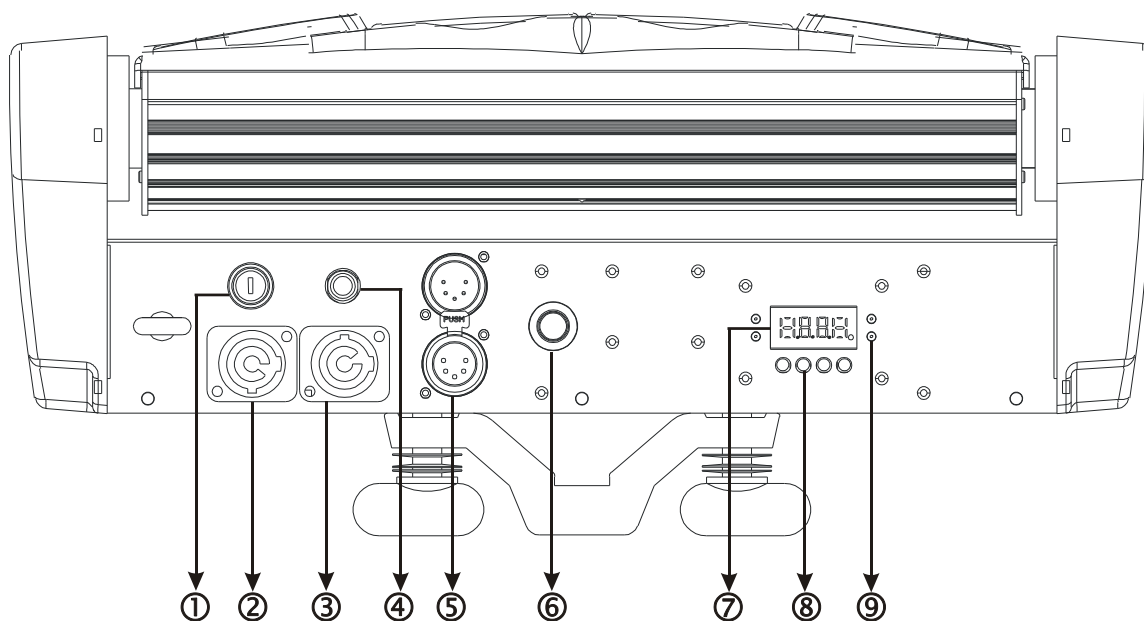

- 1. Fuse (T 3.15A):** Protects the unit from the short circuit or over-current;
- 2. POWER IN:** Connection to supply power;
- 3. POWER OUT:** Connects to supply power to the next unit;
- 4. Only for remote control:** Used to connect to the CA-8 to control the unit for Stand by, Function and Mode function;

5. DMX IN/OUT: For DMX512 linking, use 5-pin XLR cables to link the units together;

6. Microphone: Used to receive music for the sound activation;

7. Function Display: Shows the various menus and the selected functions.

8. Button:

MENU	To select the programming functions
▼ DOWN	To go backward in the selected functions
▲ UP	To go forward in the selected functions
ENTER	To confirm the selected functions

9. LED:

DMX	On	DMX input present
MASTER	On	Master Mode
SLAVE	On	Slave Mode
SOUND	Flashing	Sound activation

3.2 Main Function

To select any functions, press the **MENU** button until the required function is showing on the display. Select the function by pressing the **ENTER** button and the display will blink. Use the **DOWN** and **UP** buttons to change the mode. Once the required mode has been selected, press the **ENTER** button to setup. To go back to the functions without any changes press the **MENU** button again. Press and hold the **MENU** button for about one second or wait for about one minute to exit the menu mode.

The main functions are shown below:

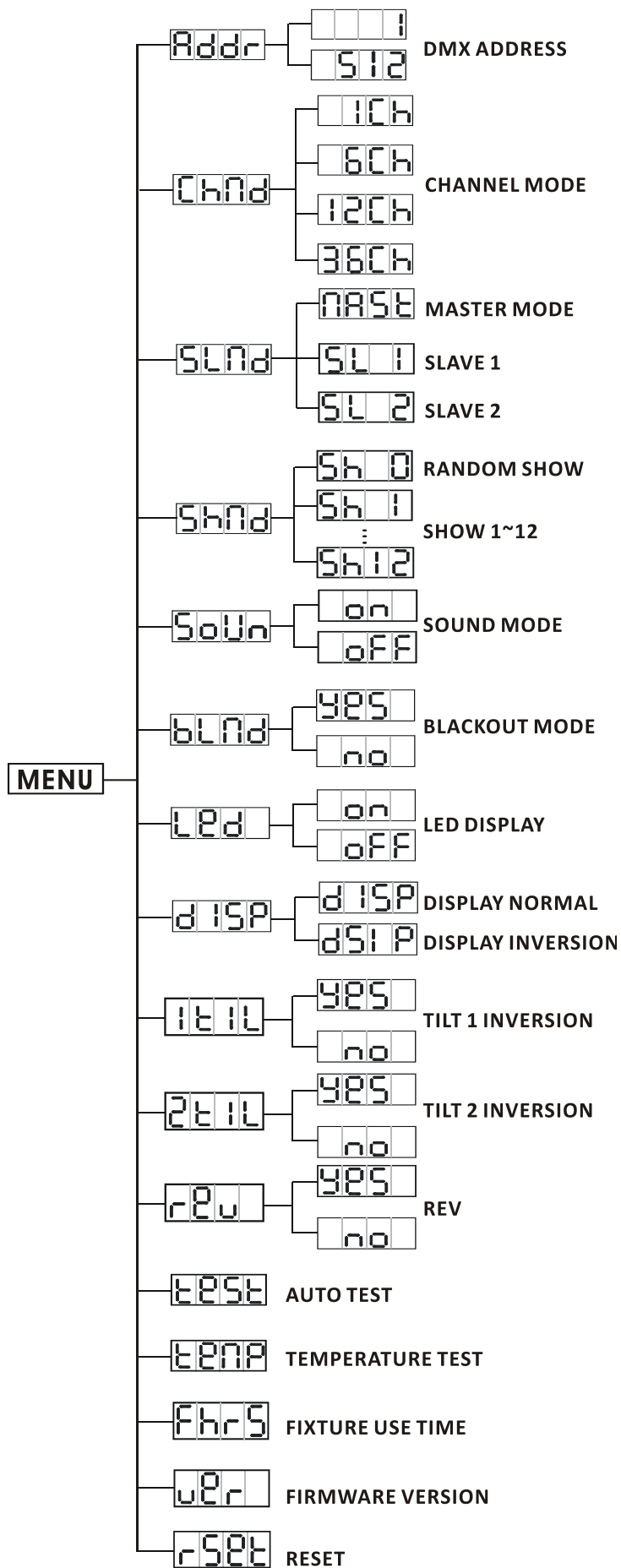

Addr DMX 512 ADDRESS

To select the **Addr**, press the **ENTER** button to show **DMX ADDRESS** on the display. Use the **DOWN/UP** buttons to adjust the address from **1** to **512**. Once the address has been selected, press the **ENTER** button to setup. To go back to the functions without any changes press the **MENU** button again. Press and hold the **MENU** button for about one second or wait for about one minute to exit the menu mode.

Chnd CHANNEL MODE

To select the **Chnd**, press the **ENTER** button to show **CHANNEL MODE** on the display. Use the **DOWN/UP** buttons to select the **1, 6, 12, 36** channel modes. Once the mode has been selected, press the **ENTER** button to setup. To go back to the functions without any changes press the **MENU** button again. Press and hold the **MENU** button for about one second or wait for about one minute to exit the menu mode.

SLnd SLAVE MODE

To select the **SLnd**, press the **ENTER** button to show **SLAVE MODE** on the display. Use the **DOWN/UP** buttons to select the **MAST** (**MASTER**), **SLV1** (**SLAVE 1**), **SLV2** (**SLAVE 2**) modes. Once the mode has been selected, press the **ENTER** button to setup, to go back to the functions without any changes press the **MENU** button again. Press and hold the **MENU** button for about one second or wait for about one minute to exit the menu mode.

Shnd SHOW MODE

To select the **Shnd**, press the **ENTER** button to show **SHOW MODE** on the display. Use the **DOWN/UP** buttons to select the **Sh0** (Random show), **Sh1** (Show 1) or ... or **Sh12** (Show 12) mode. Once the mode has been selected, press the **ENTER** button to setup. To go back to the functions without any changes press the **MENU** button again. Press and hold the **MENU** button for about one second or wait for about one minute to exit the menu mode.

SOUN SOUND MODE

To select the **SOUN**, press the **ENTER** button to show **SOUND MODE** on the display. Use the **DOWN/UP** buttons to select the **ON** (sound on) or **OFF** (sound off) mode. Once the mode has been selected, press the **ENTER** button to setup. To go back to the functions without any changes press the **MENU** button again. Press and hold the **MENU** button for about one second or wait for about one minute to exit the menu mode.

BLND BLACKOUT MODE

To select the **BLND**, press the **ENTER** button to show **BLACKOUT MODE** on the display. Use the **DOWN/UP** buttons to select the **YES** (blackout) or **NO** (normal) mode. Once the mode has been selected, press the **ENTER** button to setup. To go back to the functions without any changes press the **MENU** button again. Press and hold the **MENU** button for about one second or wait for about one minute to exit the menu mode.

LED LED DISPLAY



To select the **LED**, press the **ENTER** button to show **LED DISPLAY** on the display. Use the **DOWN/UP** buttons to select the **ON** (LED on) or **OFF** (LED off) mode. Once the mode has been selected, press the **ENTER** button to setup. To go back to the functions without any changes press the **MENU** button again. Press and hold the **MENU** button for about one second or wait for one minute to exit the menu mode.

DISP DISPLAY INVERSE



To select the **DISP**, press the **ENTER** button to show **DISPLAY** on the display. Use the **DOWN/UP** buttons to select the **DISP** (normal) or **DISP** (inversion), press the **ENTER** button to setup. To go back to the functions without any changes press **MENU** button.

TILT TILT 1 INVERSE



To select the **TILT**, press the **ENTER** button to show **TILT 1 INVERSE** on the display. Use the

DOWN/UP buttons to select the  (tilt 1 inversion) or  (normal) mode. Once the mode has been selected, press the **ENTER** button to setup. To go back to the functions without any changes press the **MENU** button again. Press and hold the **MENU** button for about one second or wait for about one minute to exit the menu mode.

TILT 2 INVERSE

To select the , press the **ENTER** button to show **TILT 2 INVERSE** on the display. Use the **DOWN/UP** buttons to select the  (tilt 2 inversion) or  (normal) mode. Once the mode has been selected, press the **ENTER** button to setup. To go back to the functions without any changes press the **MENU** button again. Press and hold the **MENU** button for about one second or wait for about one minute to exit the menu mode.

REV MODE

To select the , press the **ENTER** button to show **REV** on the display. Use the **DOWN/UP** buttons to select the  (the projector lenses will light up right to left) or  (normal, the projector lenses will light up right to left) mode. Once the mode has been selected, press the **ENTER** button to setup. To go back to the functions without any changes press the **MENU** button again. Press and hold the **MENU** button for about one second or wait for about one minute to exit the menu mode.

AUTO TEST

To select the , press the **ENTER** button to show **TEST** on the display and the unit will run a self-test . To go back to the functions without any changes press the **MENU** button again. Hold and press the **MENU** button for about one second or wait for about one minute to exit the menu mode.

TEMPERATURE

To select the , press the **ENTER** button to show **TEMP.** on the display and the display will

show the temperature of the unit . When the temperature is under 55 degrees C, the fixture works normally; when it's between 55 degrees C and 60 degrees C, the fixture will reduce the power output and when it reach 65 degrees C or higher, the LED will switch OFF. To go back to the functions without any changes press the **MENU** button again. Press and hold the **MENU** button for about one second or wait for about one minute to exit the menu mode.

Fhrs

FIXTURE HOURS

To select the **Fhrs**, press the **ENTER** button to show **FIXTURE HOURS** on the display and the display will show the number of working hours of the unit . To go back to the functions without any changes press the **MENU** button again. Press and hold the **MENU** button for about one second or wait for about one minute to exit the menu mode.

ver

SOFTWARE VERSION

To select the **ver**, press the **ENTER** button to show **SOFTWARE VERSION** on the display and the display will show the version of software of the unit . To go back to the functions without any changes press the **MENU** button again. Press and hold the **MENU** button for about one second or wait for about one minute to exit the menu mode.

rset

RESET

To select the **rset**, press the **ENTER** button to show the **RESET** on the display. Press the **ENTER** button and all channels of the unit will return to their standard position.

4. How to Control the Unit

You can operate the unit in three ways:

1. By master/slave built-in pre-program function
2. By easy CA-8 controller
3. By DMX controller

You do not need to turn the unit off when you change the DMX address, the new DMX address

setting will take effect immediately. Every time you power the unit on, it will move all the motors to their 'home' position and you may hear some movement noises for about 20 seconds. After that the unit will be ready to receive DMX signal or run the built in programs.

4.1 Master/Slave Built In Preprogrammed Function

By linking the units in master/slave connection, the first unit will control the other units to give an automatic, sound activated, synchronized light show. This function is good when you want an instant show. You have to set the first unit in master mode **MAST** and select **SH 0**(random show), **SH 1** (show 1) or ...or **SH 12** (show 12). Its DMX input jack will have nothing plugged into it, and its master LED will be constantly on and sound LED will flash to the music. The other units will have to select **SL 1** (normal) or **SL 2** (2 light show) mode, Their DMX cables plugged into the DMX input jacks (daisy chain) and the slave LED lights will be constantly on.

2-light show

In slave mode, **MAST** means the unit works as the master unit and **SL 2** means 2-light show.

In order to create a great light show, you can set **SL 2** on the second unit to get contrast movement to each other, even if you have two units only.

4.2 Easy Controller

The easy remote control is used only in master/slave mode. By connecting to the 1/4" jack socket of the first unit, you will find that the remote controller on the first unit will control all the other units for Stand by, Function and Mode selection.

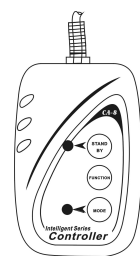

Blackout	Blackout the unit	
Function	1. Sound Strobe (Full On) 2. Auto Strobe (Full On)	Select Show Show 1-12
Mode	Random Show (LED OFF)	Show (LED ON)

4.3 DMX Controller

By using a universal DMX controller to control the units, you have to set DMX address from 1 to 512 so that the units can receive DMX signal.

Press the **MENU** button up to when **Addr** is showing on the display. Press the **ENTER** button and the display will blink. Use the **DOWN** and **UP** button to change the DMX512 address. Once the address has been selected, press the **ENTER** button to setup. To go back to the functions without any changes press the **MENU** button again.

Please refer to the following diagram to address your DMX512 channel for the first 4 units.

1 CHANNEL MODE:				
6 CHANNEL MODE:				
12 CHANNEL MODE:				
36 CHANNEL MODE:				

5. DMX512 Configuration

1/6 Channels Mode:

1 Channel Mode		6 Channels Mode				
Ch 1	Ch 1	Ch2	Ch3	Ch4	Ch5	Ch6
SHOW	TILT1 MOVEMENT	TILT2 MOVEMENT	MASTER DIMMER	STROBE	CHASE	CHASE SPEED
248-255 Random Show 228-247 Show 12 208-227 Show 11 188-207 Show 10 168-187 Show 9 148-167 Show 8 128-147 Show 7 108-127 Show 6 088-107 Show 5 068-087 Show 4 048-067 Show 3 028-047 Show 2 008-027 Show 1 000-007 Blackout				248-255 Open 240-247 Random Strobe 232-239 Open 190-231 Fast open Slow close 182-189 Open 140-181 Slow open Fast close 132-139 Open 008-131 ⚡⚡⚡ ⚡⚡ ⚡ 000-007 Open	248-255 Full On 233-247 Chase 16 218-232 Chase 15 203-217 Chase 14 188-202 Chase 13 173-187 Chase 12 158-172 Chase 11 143-157 Chase 10 128-142 Chase 9 113-127 Chase 8 098-112 Chase 7 083-097 Chase 6 068-082 Chase 5 053-067 Chase 4 038-052 Chase 3 023-037 Chase 2 008-022 Chase 1 000-007 Blackout	

12 Channels Mode:

12 Channels Mode				
Ch 1	Ch2	Ch3	Ch4	Ch5~Ch12
TILT1 MOVEMENT	TILT2 MOVEMENT	MASTER DIMMER	STROBE	COLOR LED1~LED8
			248-255 Open 240-247 Random Strobe 232-239 Open 190-231 Fast open Slow close 182-189 Open 140-181 Slow open Fast close 132-139 Open 008-131 ⚡⚡⚡ ⚡⚡ ⚡ 000-007 Open	248-255 Color change by sound 128-247 Color change slow to fast 120-127 R + G + B + W 112-119 G + B + W 104-111 R + B + W 096-103 R + G + W 088-095 R + G + B 080-087 B + W 072-079 G + W 064-071 G + B 056-063 R + W 048-055 R + B 040-047 R + G 032-039 W (White) 024-031 B (Blue) 016-023 G (Green) 008-015 R (Red) 000-007 All Off

36 Channels Mode:

36 Channels Mode (1)					
Ch1	Ch2	Ch3	Ch4	Ch5	
TILT1 MOVEMENT	TILT2 MOVEMENT	MASTER DIMMER	STROBE	RED LED 1	
			<ul style="list-style-type: none"> 248-255 [Open 240-247 [Random Strobe 232-239 [Open 190-231 [Fast open Slow close 182-189 [Open 140-181 [Slow open Fast close 132-139 [Open 008-131 [⚡⚡⚡ [⚡⚡ [⚡ 000-007 [Open 		
Ch6	Ch7	Ch8	Ch9	Ch10	Ch11
GREEN LED 1	BLUE LED 1	WHITE LED 1	RED LED 2	GREEN LED 2	BLUE LED 2

36 Channels Mode (2)

Ch12	Ch13	Ch14	Ch15	Ch16	• • •
WHITE LED 2	RED LED 3	GREEN LED 3	BLUE LED 3	WHITE LED 3	• • •
255 100% 0 0%	255 100% 0 0%	255 100% 0 0%	255 100% 0 0%	255 100% 0 0%	• • • • • •
• • •	Ch32	Ch33	Ch34	Ch35	Ch36
• • •	WHITE LED 7	RED LED 8	GREEN LED 8	BLUE LED 8	WHITE LED 8
• • • • • •	255 100% 0 0%	255 100% 0 0%	255 100% 0 0%	255 100% 0 0%	255 100% 0 0%

6. DMX Connection

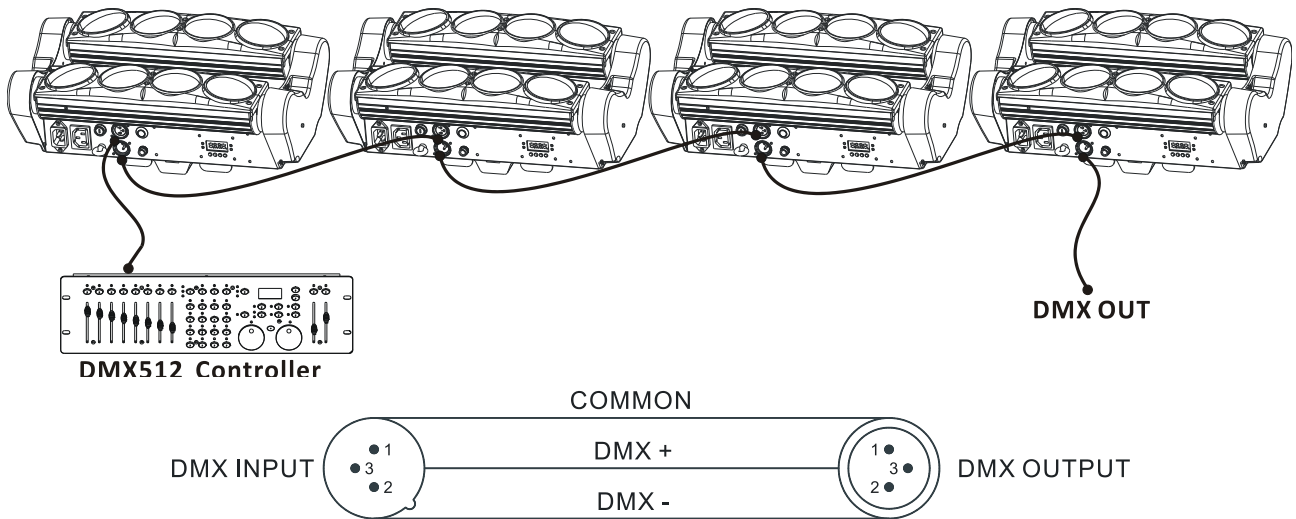

Termination reduces signal errors and to avoid signal transmission problems and interference. It is always advisable to connect a DMX terminal. (Resistance 120 ohm 1/4W) between pin2(DMX-) and pin3(DMX+) of the last fixture.

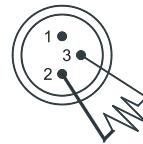

1. Connect the fixture together in a “daisy chain” by XLR plug cable from the output of the fixture to the input of the next fixture. The cable cannot be branched or split to a “Y” cable.
2. The DMX output and input connectors are pass-through to maintain the DMX circuit when one of the units’ power is disconnected.
3. The last units DMX cable has to be terminated with a 120 ohm 1/4W resistor between pin 2(DMX-) and pin 3(DMX+) of a 3-pin XLR-plug and plug it in the DMX-output of the last unit.
4. Each fixture unit needs to have an address set to receive the data sent by the controller. The address number is between 0-511 (usually 0 & 1 are equal to 1).
5. 3 pin XLR connectors are more popular than 5 pins XLR.
3 pin XLR: Pin 1: GND, Pin 2: Negative signal (-), Pin 3: Positive signal (+)
Pin 4/Pin 5: Not used.

7. Troubleshooting

Following are a few common problems that may occur during operation. Here are some suggestions for easy troubleshooting:

A. The fixture does not work, no light

1. Check the connection of power and main fuse.

B. Not responding to DMX controller

1. DMX LED should be on. If not, check DMX cables to see if linked properly.
2. If the DMX LED is on and no response to the controller, check the address settings and DMX polarity.
3. If you have intermittent DMX signal problems, check the cables of the fixture or the previous one.
4. Try another DMX controller.

C. Some fixtures don't respond to the easy controller

1. You may have a break in the DMX cabling. Check the LED for the response of the master/slave mode signal.
2. Wrong DMX address in the unit. Set the correct address.

D. No response to the sound

1. Make sure the fixture is not receiving a DMX signal.
2. Check microphone by tapping it.
3. Make sure the fixture is not set into Blackout mode

8. Fixture Cleaning

The cleaning must be carried out periodically to optimize light output. Cleaning frequency depends on the environment in which the fixture operates: damp, smoky or particularly dirty surrounding can cause greater accumulation of dirt on the unit's optics.

- Clean with soft cloth using normal glass cleaning fluid.
- Always dry the parts carefully.
- Clean the external optics at least every 30 days.

Declaration of Conformity

We declare that our products (lighting equipments) comply with the following specification and bears CE mark in accordance with the provision of the Electromagnetic Compatibility (EMC) Directive 89/336/EEC.

EN55103-1: 2009 ; EN55103-2: 2009; EN62471: 2008;
EN61000-3-2: 2006 + A1:2009 + A2:2009; EN61000-3-3: 2008.

&

Harmonized Standard

EN 60598-1:2008 + All:2009; EN 60598-2-17:1989 + A2:1991; EN 62471:2008;
EN 62493: 2010

Safety of household and similar electrical appliances
Part 1: General requirements

Innovation, Quality, Performance