

CYBERLIGHT®

CYBERLIGHT® ***CX***

CYBERLIGHT ***SV***

User Manual

© High End Systems, Inc. 2005, All Rights Reserved

Information and Specifications in this document are subject to change without notice. High End Systems, Inc. assumes no responsibility or liability for any errors or inaccuracies that may appear in this manual. The system software for the Status Cue® lighting console described in this manual is furnished under a license agreement and may be used or copied only in accordance with the terms of the agreement.

Printed in the U.S.A.

Trademarks

Trademarks used in this text: *Cyberlight*, *Intellabeam*, *Lightwave Research*, the *Lightwave Research* logo, the *High End Systems* globe logo, *Status Cue*, *Emulator*, *Trackspot*, and *LithoPatterns* are registered trademarks; and *High End Systems* and *Psy-Dye* are trademarks of High End Systems Inc.

Belden is a registered trademark of Belden, Inc. Philips is a registered trademark of Philips Lighting Company. Other trademarks and trade names may be used in this document to refer to either the entities claiming the marks and names or their products. High End Systems disclaims any proprietary interest in trademarks and trade names owned by others.

Cyberlight/Cyberlight CX/Cyberlight SV User Manual
Version 2.2 March 2005

P/N 60600016



Declaration of Conformity

according to ISO/IEC Guide 22 and EN45104

Manufacturer's name: High End Systems

Manufacturer's address:
High End Systems Inc.
2105 Gracy Farms Lane
Austin, Texas 78758
U.S.A.

Declares that the product

Product Name: Cyberlight

Product Number: CBL-01 CL Litho
CBL-CX CX Litho
CBL-SV SV Litho

Product Options: All

conforms to the following EEC directives:

73/23/EEC, as amended by 93/68/EEC
89/336/EEC, as amended by 92/31/EEC and 93/68/EEC

Equipment referred to in this declaration of conformity was manufactured in compliance with the following standards beginning in 1995:

Safety: EN 60598-1 : 1993
EN 60598-2-17 : 1989
A1-A3 : 1993

EMC: EN 50081-1 : 1992
EN 50082-1 : 1992



Lanny Derryberry, Compliance Engineer
U.S.A., December 20, 1996

IMPORTANT SAFETY INFORMATION

INSTRUCTIONS PERTAINING TO CONTINUED PROTECTION AGAINST FIRE, ELECTRIC SHOCK, EXPOSURE TO EXCESSIVE ULTRAVIOLET (UV) RADIATION, AND INJURY TO PERSONS ARE FOUND IN APPENDIX E.

PLEASE READ ALL INSTRUCTIONS PRIOR TO ASSEMBLY, MOUNTING, AND OPERATING THIS EQUIPMENT.

IMPORTANT: INFORMATIONS DE SÉCURITÉ

INSTRUCTIONS RELATIVES À UNE PROTECTION CONTINUE CONTRE L' INCENDIE, LE CHOC ÉLECTRIQUE, L' EXPOSITION AUX RADIATIONS ULTRAVIOLETTES EXCESSIVES ET CONTRE DES BLESSURES POSSIBLES SUR DES INDIVIDUS SE TROUVENT DANS L'APPENDICE E.

PRIÈRE DE LIRE TOUTES LES PRÉCAUTIONS ET LES AVERTISSEMENTS AVANT D'ASSEMBLER, DE MONTER, ET DE FAIRE FONCTIONNER CET ÉQUIPEMENT.

WICHTIGE SICHERHEITSHINWEISE

DIE NACHSTEHENDEN HINWEISE BETREFFEN DEN SCHUTZ GEGEN BRAND, ELEKTRISCHEN SCHLAG, ÜBERHÖHTE UV-STRAHLUNG SOWIE VERLETZUNGEN. SIE BEFINDEN SICH IN APPENDIX E.

LESEN SIE ALLE WARNUNGEN SORGFÄLTIG, BEVOR SIE DAS GERÄT ZUSAMMENBAUEN, INSTALLIEREN UND BENUTZEN!

INFORMACIÓN IMPORTANTE DE SEGURIDAD

SE ENCUENTRAN EN EL APÉNDICE E LAS INSTRUCCIONES CONCERNIENTES A LA PROTECCIÓN CONTINUA CONTRA INCENDIO, CHOQUE ELÉCTRICO, EXPOSICIÓN EXCESIVA A RAYOS ULTRAVIOLETAS Y LESIONES A PERSONAS.

POR FAVOR LEA TODAS LAS PRECAUCIONES Y LAS ADVERTENCIAS ANTES DE ENSAMBLAR, MONTAR Y OPERAR ESTE EQUIPO.

INFORMAZIONI IMPORTANTI DI SICUREZZA

ISTRUZIONI PERTINENTI LA PROTEZIONE CONTRO IL FUOCO, LE SCOSSE ELETTRICHE, L' ECCESSIVA ESPOSIZIONE AI RAGGI ULTRAVIOLETTI I DANNI ALLE PERSONE SI TROVANO NEL APPENDICE E.

LEGGERE TUTTI GLI AVVERMENTI PRIMA DI MONTARE E USARE QUESTO APPARECCHIO.

FCC Information

This equipment has been tested and found to comply with the limits for a Class A digital device, pursuant to part 15 of the FCC rules. These limits are designed to provide reasonable protection against harmful interference when the equipment is operated in a commercial environment. This equipment generates, uses, and can radiate radio frequency energy and, if not installed and used in accordance with the instruction manual, may cause harmful interference to radio communications. Operation of this equipment in a residential area is likely to cause harmful interference in which case the user will be required to correct the interference at his own expense.

Warranty Information

Limited Warranty

Unless otherwise stated, your product is covered by a two year parts and labor limited warranty. Dichroic filters and LithoPatterns® high resolution glass gobos are not guaranteed against breakage or scratches to coating. It is the owner's responsibility to furnish receipts or invoices for verification of purchase, date, and dealer or distributor. If purchase date cannot be provided, date of manufacture will be used to determine warranty period.

Returning an Item Under Warranty for Repair

It is necessary to obtain a Return Authorization number (RA#) from your dealer or point of purchase **BEFORE** any units are returned for repair. The manufacturer will make the final determination as to whether or not the unit is covered by warranty. Lamps are covered by the lamp manufacturer's warranty.

Any Product unit or parts returned to High End Systems must be packaged in a suitable manner to ensure the protection of such Product unit or parts, and such package shall be clearly and prominently marked to indicate that the package contains returned Product units or parts and with a Returned Authorization (RA#) number. Accompany all returned Product units or parts with a written explanation of the alleged problem or malfunction.

Please Note: Freight Damage Claims are invalid for fixtures shipped in non-factory boxes and packing materials.

Freight

All shipping will be paid by the purchaser. Items under warranty shall have return shipping paid by the manufacturer only in the Continental United States. **Under no circumstances will freight collect shipments be accepted.** Prepaid shipping does not include rush expediting such as air freight. Air freight can be sent customer collect in the Continental United States.

REPAIR OR REPLACEMENT AS PROVIDED FOR UNDER THIS WARRANTY IS THE EXCLUSIVE REMEDY OF THE CONSUMER. HIGH END SYSTEMS, INC. MAKES NO WARRANTIES, EXPRESS OR IMPLIED, WITH RESPECT TO ANY PRODUCT, AND HIGH END SPECIFICALLY DISCLAIMS ANY WARRANTY OF MERCHANTABILITY OR FITNESS FOR A PARTICULAR PURPOSE. HIGH END SHALL NOT BE LIABLE FOR ANY INDIRECT, INCIDENTAL OR CONSEQUENTIAL DAMAGE, INCLUDING LOST PROFITS, SUSTAINED OR INCURRED IN CONNECTION WITH ANY PRODUCT OR CAUSED BY PRODUCT DEFECTS OR THE PARTIAL OR TOTAL FAILURE OF ANY PRODUCT REGARDLESS OF THE FORM OF ACTION, WHETHER IN CONTRACT, TORT (INCLUDING NEGLIGENCE), STRICT LIABILITY OR OTHERWISE, AND WHETHER OR NOT SUCH DAMAGE WERE FORESEEN OF UNFORESEEN.

Warranty is void if the product is misused, damaged, modified in any way, or for unauthorized repairs or parts. This warranty gives you specific legal rights, and you may also have other rights which vary from state to state.

Contents

Introduction

Cyberlight Features	intro-1
About This Manual.....	intro-3
Caution, Warning and Explosion Symbols	intro-4
Getting Help	intro-4

Chapter 1 Installation and Setup

Unpacking the Cyberlight Fixture.....	1-2
Specifications	1-3
The Cyberlight Family of Fixtures.....	1-6
Optional Accessories.....	1-7
Identifying Rear Panel Components	1-8
Obtaining and Installing the Power Cord Cap	1-9
Setting the Cyberlight Fixture Voltage	1-10
Installing the Yoke	1-14
Installing or Replacing the MSR 1200 Lamp.....	1-16
Installing SV Color Wheel Dichroic Filters.....	1-19
Setting the Personality DIP Switches.....	1-22
Rear Panel LED Indicators.....	1-27
Putting the Fixture Into Use	1-28
Where to Go From Here	1-30

Chapter 2 Using Your Cyberlight

Choosing DMX 512 or LWR Protocol	2-2
Implementing DMX/LWR Control.....	2-3
Obtaining Cabling and Terminators.....	2-6
Linking the Fixtures to the Controller.....	2-8
Mounting the Fixture.....	2-9
Troubleshooting	2-12

Chapter 3 Servicing Your Cyberlight

General Maintenance and Cleaning	3-2
Replacing Parts.....	3-15
Adjustments.....	3-23

Appendix A	DMX Control of Cyberlight	
	Overview	A-1
	Address DIP Switches	A-2
	Related Topics	A-2
	Accessing Control Information	A-2
	Rounding Conventions	A-2
	DMX 512 Mode 1 – Standard Cyberlight DMX Control.....	A-3
	DMX 512 Mode 2 – Enhanced Cyberlight DMX Control	A-7
	DMX 512 Mode 3 – Cyberlight 15-Channel DMX Control	A-13
	Channel Boundaries.....	A-18
Appendix B	Cyberlight Mirror Movement Times	
Appendix C	Factory-Installed Wheels	
Appendix D	Typical Voltages Worldwide	
Appendix E	Important Safety Information	
Glossary		
Index		

Table of Figures

Figure 1-1. Identifying Cyberlight rear panel components.	1-8
Figure 1-2. View of the bottom of the Cyberlight fixture, where the access door latches are located.....	1-11
Figure 1-3. Removing the first four rear panel screws in order to access the Cyberlight voltage selection jumpers.	1-12
Figure 1-4. In order to remove the lamp box access door, you need to remove the last two 5/32 inch allen screws, which are located by the color mixing and dim flags.	1-12
Figure 1-5. On CL and CX models, make sure you disconnect the fan power wires from the fan connectors before removing the lamp box access door.	1-13
Figure 1-6. Location of the voltage selection jumpers and the voltage selection wire.	1-13
Figure 1-7. Location of the voltage selection tabs and connector.	1-13
Figure 1-8. Components of the Cyberlight yoke.	1-14
Figure 1-9. Installing the yoke on the Cyberlight fixture.	1-15
Figure 1-10. Location of lamp assembly and optimization screws.	1-16
Figure 1-11. Removing the lamp from its socket.	1-17
Figure 1-12. Installing the new lamp into the socket.	1-17
Figure 1-13. Placing Cyberlight fixture in setup mode allows you to perform the necessary lamp optimization prior to using a newly-installed lamp.	1-18
Figure 1-14. Removing the center access door.	1-20
Figure 1-15. The color wheel is located between the effects wheel and the color mixing flags, opposite the rotating litho wheel.	1-20
Figure 1-16. High End Systems recommends you replace the CL color correction filter (at position 4) with the salmon-colored CTO correction filter, and the aqua filter (at position 5) with the homogenizing frost filter.	1-21
Figure 1-17. Push the dichroic filter toward the large retaining tab to free it from the wheel clips.	1-21
Figure 1-18. Orient the coated side of the dichroic toward the lamp and the uncoated side toward the static litho wheel.	1-22
Figure 1-19. The personality switches.	1-22
Figure 1-20. The Cyberlight rear panel LEDs give you information about the Cyberlight fixture's lamp, fixture voltage, operating temperature, data transmission and reception, and other factors.	1-24
Figure 1-21. Setting the Cyberlight power switch to the ON and OFF positions. ..	1-29
Figure 2-1. The address switch block allows you to select the control protocol (DMX 1, DMX 2, DMX 3, or LWR) and the fixture number.	2-4
Figure 2-2. Properly-constructed data cable.	2-6
Figure 2-3. Constructing a data cable terminator.	2-7

Figure 2-4. Make sure you connect the Data Out connector from the previous Cyberlight to the Data In connector of the next Cyberlight. Also, you must terminate the Data Out connector of the last device in the link (whether the last device is a Cyberlight or something else).	2-8
Figure 2-5. Attaching two C-clamps to the Cyberlight yoke.	2-11
Figure 2-6. Always use suitable safety cables when hanging a Cyberlight from a truss or any other support system. The safety cable can be looped around the support and the Cyberlight yoke once or twice; loop it twice if this will help prevent the fixture from rotating, thus possibly loosening the clamp mounting bolt.	2-11
Figure 2-7. Loosening the hub screws allows you to adjust the wheel's clearance.	2-18
Figure 2-8. Loosen these two allen screws to adjust the rotating litho wheel.	2-19
Figure 2-9. The rotating litho wheel's spring plunger must always contact the rotating litho wheel.	2-19
Figure 3-1. Holding the fan fins in place while you clean the fans using compressed air.	3-3
Figure 3-1. Bottom view of the Cyberlight fixture.	3-4
Figure 3-2. Locations of the iris, power lens, focusing lens, zoom lens and mirror.	3-5
Figure 3-3. Locations of the Cyberlight motors.	3-5
Figure 3-4. Close the iris by rotating the large black gear located on top of the iris motor.	3-6
Figure 3-5. Cleaning the anti-reflective glass.	3-6
Figure 3-6. Removing the standoff between the iris motor and the color wheel.	3-7
Figure 3-7. Make sure the wheel is positioned with the keyhole slots facing downward before removing it.	3-7
Figure 3-8. The homing slot is a small groove on the outside edge of the wheel. The static litho wheel and the color wheel's homing slots are in different locations. The effects wheel does not have a homing slot.	3-8
Figure 3-9. Clean the groove in the wheel sensor.	3-8
Figure 3-10. Static litho wheel lithos must be oriented with the coated/etched side facing away from the lamp.	3-9
Figure 3-11. Color wheel dichroic filters should be oriented with the coated side of the dichroic facing toward the lamp and the glass side facing toward the static litho wheel.	3-9
Figure 3-12. Position the keyhole slots so they fit over both hex screws as well as the "slider" screw inset in the hub.	3-10
Figure 3-13. Location of lamp assembly and optimization screws.	3-11
Figure 3-14. Removing the lamp from its brass socket.	3-11

Figure 3-15. Location of the first four rear panel screws you need to remove in order to access the lamp assembly.	3-12
Figure 3-16. In order to remove the lamp box access door, you need to remove the last two 5/32 inch allen screws, which are located by the color mixing and dim flags.	3-12
Figure 3-17. On CL and CX models, make sure you disconnect the fan power wires from the fan connectors before removing the lamp box access door.	3-13
Figure 3-18. Locations of the reflector and infrared filter.	3-13
Figure 3-19. Location of the color mixing flags and dim flags.	3-14
Figure 3-20. View of the bottom of the Cyberlight fixture, where the access door latches are located.	3-16
Figure 3-21. Removing the rear panel screws allows you to access the Cyberlight voltage selection jumpers.	3-16
Figure 3-22. In order to remove the lamp box access door, you need to remove the last two 5/32 inch allen screws, which are located by the color mixing and dim flags.	3-17
Figure 3-23. On CL and CX models, make sure you disconnect the fan power wires from the fan connectors before removing the lamp box access door.	3-17
Figure 3-24. Location of power supply board fuses.	3-18
Figure 3-25. Removing the center access door.	3-19
Figure 3-26. Insert the new or cleaned litho into the rotating litho housing as described above; improper installation can cause heat damage to the litho.	3-20
Figure 3-27. Turn on the spring as you push it into the rotating litho housing.	3-20
Figure 3-28. Make sure the end of the spring fits under any one of the three retaining washers, as shown above.	3-21
Figure 3-29. Do not place the end of the spring between the three retaining washers.	3-21
Figure 3-30. Push the dichroic/litho toward the large retaining tab to free it from the wheel tabs.	3-22
Figure 3-31. Adjusting the Cyberlight CX mechanical zoom lens.	3-23
Figure 3-32. Loosen the three 5/32 inch allen screws and the T-handle to adjust the mirror head deviation.	3-24
Figure 3-33. Grasp both sides of the mirror head and rotate it to the desired position.	3-25
Figure 3-34. Be sure to note the deviation angle in case you need to set other fixtures for the same deviation, or if you want to use this exact deviation again. For example, the figure above has about a 10° + (plus) deviation.	3-25
Figure 3-35. Adjust the yoke handles on both sides of the Cyberlight to tilt the fixture in a specific way.	3-26

Figure A-1. The DMX address switch block allows you to select the control protocol (DMX 1, DMX 2, DMX 3, or LWR) and the fixture number.	A-2
Figure A-2. Unplanned channel addressing wastes DMX addresses because of fixture boundary overlap.	A-20
Figure A-3. Planned channel addressing wastes a minimum of DMX address space.	A-20
Figure C-1. Factory configuration of the CX static litho wheel.	C-1
Figure C-2. Factory configuration of the CL/SV static litho wheel.	C-2
Figure C-3. Factory configuration of the CX rotating litho wheel.	C-3
Figure C-4. Factory configuration of the CL/SV rotating litho wheel.	C-4
Figure C-5. Factory configuration of the CX color wheel.	C-5
Figure C-6. Factory configuration of the CL/SV color wheel.	C-6
Figure C-7. Effects wheel for the CL, CX and SV models.	C-7

Table of Tables

Table 1-1: Cyberlight Optional Accessories	1-7
Table 1-2: Cyberlight Information Mode	1-24
Table 1-3: Description of Cyberlight Rear Panel LEDs	1-27
Table 2-1: Protocol Mode Switch Settings	2-5
Table 2-2: Cyberlight Fixture Number Settings (LWR Protocol)	2-5
Table 2-3: XLR Cable Pinouts	2-7
Table 3-1: Description and Function of Power Supply Board Fuses	3-18
Table A-1: Addressing Fixtures in 20-Channel DMX 512 Mode 1	A-3
Table A-2: Cyberlight DMX Assignments Mode 1	A-3
Table A-3: Addressing Fixtures in 20 Channel DMX 512 Mode 2	A-7
Table A-4: Cyberlight DMX Assignments Mode 2	A-8
Table A-5: Addressing Fixtures in 15 Channel DMX 512 Mode 3	A-13
Table A-6: Cyberlight DMX Assignments Mode 3	A-14
Table A-7: 20-Channel Addresses (Modes 1 and 2)	A-18
Table A-8: 15-Channel Addresses (Mode 3)	A-19

Introduction

Congratulations on your purchase of the Cyberlight® automated luminaire manufactured by High End Systems, Inc. Cyberlight – the most advanced intelligent lighting instrument available — is ideal for theatrical applications, stage, studio, concert touring, and nightclubs. Cyberlight provides designers and operators with a *luminaire* (fixture) of unprecedented brightness, speed, accuracy and effects for complex lighting cues and scenes.

Your microprocessor-based Cyberlight fixture responds to an extensive set of programming commands called *constructs*. You can easily program these constructs through the Status Cue system, the Cyberlight LCD controller or another standard DMX controller into simple or complex scenes and sequences. Examples of constructs are colors, color mixing, lithos, litho mixing, rotating lithos, special effects, variable frost, dim, iris, and strobing.

This manual covers the Cyberlight versions listed below:

- **Cyberlight:** The full-featured luminaire, with motorized variable frost from hard edge to soft edge; beam position and movement speed; focus; variable zoom; litho and CYM (cyan-yellow-magenta) color selection; color mixing; variable iris; variable-speed rotating lithos (0-50 RPM); full optical dimming; and automatic cooling system shutdown. Additionally, the fixture accepts stock and custom LithoPatterns, including Psy-Dye™ high resolution glass gobos, Art Glass and Special Effects lithos.
- **Cyberlight Studio Version (SV):** The quieter-operating, full-featured luminaire.
- **Cyberlight CX:** The value-priced luminaire, with all of the features of the Cyberlight except motorized zoom, color mixing and variable frost.

Cyberlight® Features

The Cyberlight features can be categorized into four main areas, listed separately below: control/information features, lamp, optics, effects, and other features.

Control/information features

- Remote system enable/disable.
- “Info” LED displays lamp hours, lamp strikes, lamp voltage, lamp current, fixture voltage, fixture temperature, and the fixture version number for at-a-glance monitoring (no controller is required).
- Can be controlled by Lightwave Research (LWR) or standard USITT DMX 512 protocol:
 - Use LWR protocol for online software uploads and control with High End Systems’ top-of-the-line Status Cue system, for uploads only with the Cyberlight Upload Module, and for control only with the Cyberlight LCD controller.
 - Use DMX 512 protocol if the Cyberlight is on the same link as other vendors’ control equipment.

Lamp

- 1200 watt MSR/MSD lamp; 5600° Kelvin color temperature
- 750-hour rated lamp life
- Quick lamp change and optimization

Optics

- Computer-optimized reflector and lens assembly for maximum output
- Enhanced mirror increases efficiency
- Motorized zoom control (Cyberlight CL and SV models only; the CX has a 3-position zoom at 12°, 14°, and 18°)
- Zoom angle 12° to 18°—Cyberlight CL and SV only
- Motorized focus control
- Motorized variable frost from hard edge to soft edge
- Smooth, precise micro-stepped beam positioning
- 100% dimming, fade to black
- 170° pan – 110° degrees tilt
- Break-resistant mirror

Effects

- 16 million colors available via sophisticated dichroic subtractive CYM (cyan-yellow-magenta) color model—Cyberlight CL and SV only
- Eight-position indexed color wheel with a versatile selection of richly-saturated dichroic colors plus open (white), custom dichroic filters available
- Upward, downward, and centered color correction
- Variable speed (forward and reverse 0-50 RPM) rotating lithos (from 0° to 360°) with replaceable patterns (4 lithos plus open)
- Eight-position fixed litho wheel with seven easily-replaceable LithoPatterns glass lithos standard
- Litho mixing effects: rotating over fixed, or fixed over fixed
- Eight-position effects wheel, including multi-image prism effect, split color effect and subtractive color dichroic mosaic effect
- Infinitely-variable frost effect—Cyberlight CL and SV only
- De-focus lens effect
- Variable speed motorized iris control
- Variable high-speed strobe shutter (1 to 10 FPS)
- Variable speed mirror scan, litho, and color changes

Other features

- Pan and tilt swap; pan and tilt invert
- Selectable voltage and frequency
- Circuit breaker protection
- Six transport handles
- High-resolution stepper motors
- Durable black powder coat finish
- Yoke indexing with graduated scale reduces pre-focus time
- Adjustable mirror head deviation ± 20 degrees (pan)
- Thermal overload protection
- Power factor correction
- Meets international standards for safety and electromagnetic compatibility

About This Manual

This manual covers the following topics in its three chapters and five appendices:

- **Chapter 1:** Unpacking your Cyberlight and preparing it for use.
- **Chapter 2:** Putting the Cyberlight into operation, including the “how-tos” of DMX 512 and LWR control protocols, connecting the fixture to a controller and mounting the fixture. Troubleshooting suggestions are also included.
- **Chapter 3:** Routine maintenance and service.
- **Appendix A:** Explains the three DMX modes and how to use them.
- **Appendix B:** Cyberlight mirror movement times.
- **Appendix C:** Shows the factory configuration for the color, effects, static litho and rotating litho wheels.
- **Appendix D:** Typical voltage/frequency settings worldwide, based on High End Systems Inc.’s experience.
- **Appendix E:** Important safety information.
- **Glossary**
- **Index**

Caution, Warning and Explosion Symbols

The following three international symbols appear in margins throughout this manual to highlight caution and warning messages.



Caution: This symbol appears adjacent to Caution messages. Not heeding these messages could result in personal injury and damage to equipment.



Warning: This symbol appears adjacent to High Voltage Warning messages. Not heeding these messages could result in serious personal injury.



Explosion: This symbol appears adjacent to Explosion warning messages.

Getting Help

U.S. and Canada	From 8 a.m. to 5 p.m. (U.S. Central time) Monday through Friday: (800) 890-8989
	24-hour FAX: (512) 834-9195
	24-hour voice mail: (512) 837-3063 or (800) 890-8989
	24-hour BBS: (512) 339-3043
24-hour World Wide Web site	http://www.highend.com
Europe	Voice: +49 8122 9903-0 FAX: +49 8122 9903-33
Singapore	Voice: +65 742 8266 FAX: +65 743 9322

Chapter 1

Installation and Setup

Unpacking the Cyberlight Fixture	1-2
Save the Shipping Materials	1-2
Inspecting the Contents	1-2
Specifications.....	1-3
Model and Part Numbers.....	1-3
Physical Specifications	1-3
Electrical Specifications	1-4
Safety Standards	1-4
Safety Specifications	1-4
Cables and Connectors	1-5
The Cyberlight Family of Fixtures	1-6
Nomenclature	1-6
Optional Accessories	1-7
Identifying Rear Panel Components.....	1-8
Obtaining and Installing the Power Cord Cap.....	1-9
Important Power Cord Cap Information - U.K. Only	1-9
VIGTIG FIKKER HEDS INFORMATION - DANMARK	1-10
Setting the Cyberlight Fixture Voltage.....	1-10
Changing the Voltage Selection Jumpers.....	1-11
Installing the Yoke.....	1-14
Installing or Replacing the MSR 1200 Lamp.....	1-16
Resetting the Information Counter	1-18
Optimizing the Cyberlight Fixture Lamp.....	1-18
Installing SV Color Wheel Dichroic Filters	1-19
Setting the Personality DIP Switches	1-22
Personality Switch Setting Descriptions	1-23
Switch 1: Self-Test	1-23
Switch 2: Setup Mode	1-23
Locating the Information LED.....	1-24
Switches 3, 4, and 5: Information Mode	1-24
Interpreting the Information LED	1-25
Switch 6: Pan Invert	1-26
Switch 7: Tilt Invert.....	1-26
Switch 8: Pan/Tilt Swap.....	1-26
Rear Panel LED Indicators	1-27
Putting the Fixture Into Use.....	1-28
Setting the Cyberlight Power Switch	1-29
Where to Go From Here	1-30

Unpacking the Cyberlight[®] Fixture

First, unpack your fixture and verify that it arrived complete and without any damage.

Save the Shipping Materials

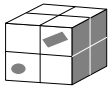

Do not discard the shipping carton and packing materials. The carton and packing materials are specifically designed to protect the product during transport.

High End Systems assumes no responsibility for products damaged during transport. Therefore, you should return a product for repair in its original shipping carton and packing materials.

Note Before sending anything to the factory, be sure to call your HES dealer/distributor for a Return Authorization (RA) number. The factory cannot accept any goods shipped without an RA number.

Inspecting the Contents

Carefully unpack the carton and inspect the contents for damage. If any of the items in the following list are missing or damaged you must notify both the shipping agent and your sales agent immediately.

- One copy of this manual
- One Cyberlight fixture
- One MSR 1200 lamp (packaged in a separate box)
- One yoke enclosed in cardboard packaging with a yoke handle kit consisting of two yoke handles, two 5/16 inch carriage bolts, two 5/16 inch allen screws, and two 9/16 inch locknuts
- *SV only:* Two color wheel dichroic filters enclosed in individual containers (one CTO correction filter, one homogenizing frost filter)

Specifications

This section lists specifications for the Cyberlight family of fixtures.

Model and Part Numbers

- **Models:** Cyberlight, Cyberlight CX, Cyberlight SV
- **Manufacturer:**
High End Systems, Inc.
2105 Gracy Farms Lane
Austin, Texas, 78758
USA
- **Product Numbers:**
CL Litho
CX Litho
SV Litho

Physical Specifications

- **Fixture weight:**
42.23 kg (92.9 lb) for Cyberlight
39.77 kg (87.5 lb) for Cyberlight CX
44.32 kg (97.5 lb) for Cyberlight SV
- **Yoke weight:** 1.27 kg (2.8 lb)
- **Total fixture weight:**
45.6 kg (95.7 lb) Cyberlight
41.04 kg (90.3 lb) Cyberlight CX
45.59 kg (100.3 lb) Cyberlight SV
- **Dimensions (CL and CX):** cm: 106.7 L x 33.0 W x 31.7 H
in: 42.0 L x 13.0 W x 12.48 H
- **Dimensions (SV):** cm: 106.7 L x 33.0 W x 36.6 H
in: 42.0 L x 13.0 W x 14.41 H
- **Dimensions with handles (all models):**
add 5.08 cm (2 in) to length
and 7.62 cm (3 in) to width
- **Lamp type:** Use 1200 W, G-22 Base, MSR 1200 or MSD 1200 Metal Halide Lamp Only

Electrical Specifications

- **Voltage selectable:** 208V / 230V only
- **Power consumption:** 6.3/6.3A
- **Rated power:** 1300W
- **Rated frequency:** 50-60Hz
- **Power Factors:** 230V, 50Hz: 0.85
208V, 60Hz: 0.97



- (1) **Class I equipment - For continued protection against electric shock connect this equipment to an earthed (grounded) power source only.**
- (2) **This equipment for connection to branch circuit having a maximum overload protection of 20 A.**

Safety Standards

- Safety standards
 - EN 60598-1 : 1993
 - EN 60598-2-17 : 1989
A1-A3 : 1993
- EMC Standards
 - EN 50081-1 : 1992
 - EN 50082-1 : 1992

Safety Specifications

- Maximum ambient temperature: 50° C (122° F)
- Maximum exterior surface temperature: 62° C (144° F)
- Minimum distance to lighted object: 1.0 m (3.28 ft.)
- Minimum distance to flammable objects: 1.0 m (3.28 ft.)
- Maximum winding temperature, Tw: 180° C (356° F)
- Maximum capacitor temperature, Tc: 85° C (185° F)



- **Do not mount on a flammable surface.**
- Not for residential use.
- Use in dry locations only.



Cables and Connectors

- **DMX data cables:** Belden[®] 9841 or equivalent (meets specifications for EIA RS-485 applications) with characteristics listed below:
 - 2-conductor twisted pair plus a shield
 - maximum capacitance between conductors - 30 pF/ft.
 - maximum capacitance between conductor and shield - 55 pF/ft.
 - maximum resistance of 20 Ω /1000 ft.
 - nominal impedance 100–140 Ω
 - 22–24 AWG with insulation having a dielectric rating of 300 volts or higher
- **DMX data connectors:** Standard 3-pin male and female XLR connectors
- **DMX data terminators:** Male XLR connector with 120 ohm terminator (see Chapter 2)

The Cyberlight[®] Family of Fixtures

Currently, the Cyberlight family of automated luminaires (fixtures) consists of three models:

The Cyberlight (referred to in this manual as the *CL* model):

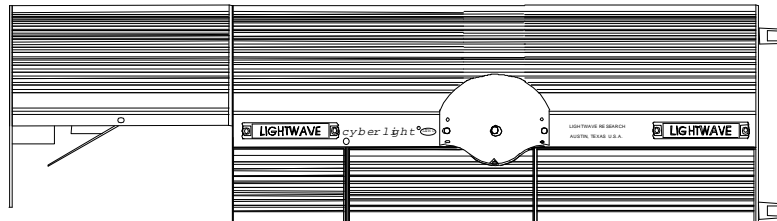

The Cyberlight SV (referred to in this manual as the *SV* model):

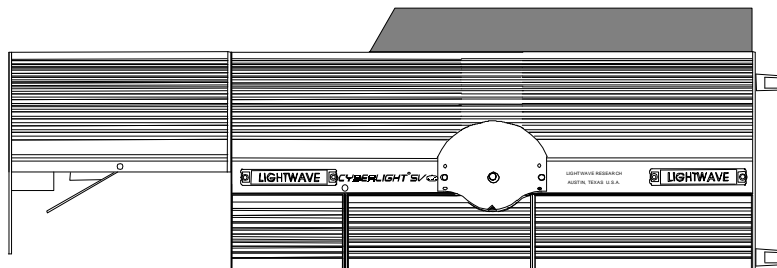

The Cyberlight CX (referred to in this manual as the *CX* model):

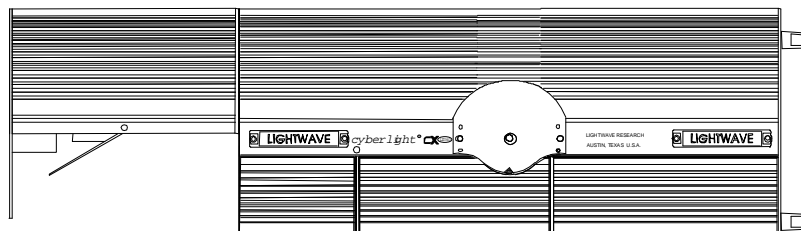

Nomenclature

Because all three Cyberlight models have different features and functions, some references in this manual will be to one specific model only. Other references might encompass all three models. The following nomenclature system will be used throughout this manual so you will know which fixture model is being referred to:

- A generic reference to *Cyberlight* applies to all three models (CL, CX and SV).
- A reference to *CL* applies to the Cyberlight CL only.
- A reference to *CX* applies to the Cyberlight CX only.
- A reference to *SV* applies to the Cyberlight SV only.

Optional Accessories

Table 1-1 below shows the optional accessories for Cyberlight available from your High End Systems dealer/distributor:

Table 1-1. Cyberlight Optional Accessories

Name	Part Number
Status Cue controller	Call*
Cyberlight LCD controller with unprogrammed RAM card	19020001
Unprogrammed RAM card	80440017
Replacement MSR 1200 lamp	55030001
Cyberlight LithoPatterns	Call*
Cyberlight custom color wheel dichroic filters	Call*
Cyberlight touring yoke kit	55040005
Cyberlight dust filter kit	55040006
Cyberlight narrow angle lens kit	55040012
Keal road case (1 fixture)	19070001
Keal road case (2 fixtures)	19070001
Heavy duty 3-pin XLR cable (10')	55050005
Heavy duty 3-pin XLR cable (25')	55050006
Heavy duty 3-pin XLR cable (50')	55050007
Heavy duty 3-pin XLR cable (100')	55050008
Galvanized safety cable	12040001
Deluxe C-clamp	55000004

Call* - Contact either your High End Systems dealer/distributor, High End Systems Sales, or the High End Systems World Wide Web site. The Web site includes product information and pictures of all currently-available LithoPatterns.

High End Systems International Sales: See the inside title page of this manual

High End Systems World Wide Web site: <http://www.highend.com>

Identifying Rear Panel Components

This section describes the rear panel components, LEDs, switches, and connectors.

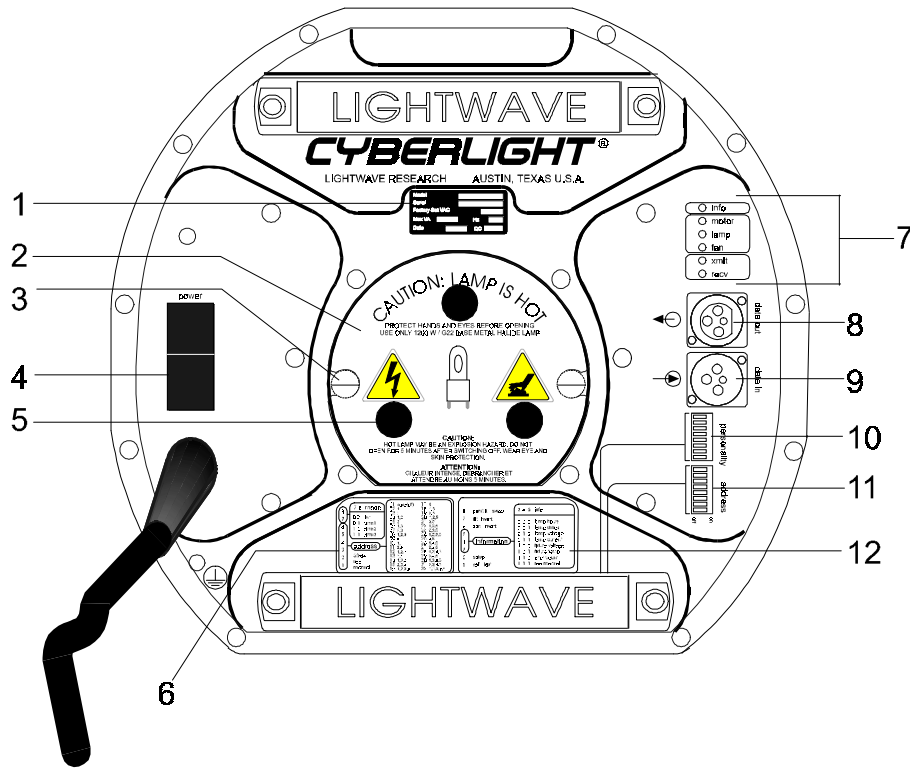

Figure 1-1. Identifying Cyberlight rear panel components.

1. **Quality Control (QC) plate** - displays (from top to bottom) the fixture’s model number, serial number, factory voltage setting, maximum volts and amps, manufacturing date and the initials of the engineer responsible for Quality Control (QC) of the fixture.
2. **Lamp Assembly** – removable from the rear of the fixture for easy lamp replacement (see “Installing or Replacing the MSR 1200 Lamp” on page 1-16).
3. **Lamp Assembly Retaining screws** – these two screws fasten the lamp assembly to the fixture (see “Installing or Replacing the MSR 1200 Lamp” on page 1-16).
4. **Power On/Off Switch** – press the “I” side to turn fixture power ON. Press the “O” side to turn fixture power OFF.
5. **Lamp Optimization Screws** – these three screws align the lamp for optimal output (see page 1-18).
6. **Address DIP Switch Settings** – this chart lists the fixture number settings and shows how to select either Lightwave Research (LWR) control protocol or one of three DMX 512 modes (see “What is DMX 512 Protocol?” on page 2-2).

7. **Status and Information LEDs** – these LEDs provide the following information:
 - the top LED displays pertinent fixture information, such as lamp hours, strikes, current, and so on (see page 1-23 and page 1-24)
 - the middle three LEDs display status of the motors, lamp, and fans (see page 1-27)
 - the bottom two LEDs blink when data is transmitted to or received from a controller (see page 1-27)
8. **Data Out XLR Connector** – connect this to the Data In connector of the next device in the link (see “Linking the Fixtures to the Controller” on page 2-8).
9. **Data In XLR Connector** – connect an XLR cable from the Data Out connector of the previous device in the link (see “Linking the Fixtures to the Controller” on page 2-8).
10. **Personality DIP Switches** – use these switches to set the operating mode of the fixture (see page 1-22).
11. **Address DIP Switches** – use these switches to set the fixture address and to select the control protocol (see “Setting the Address DIP Switches” on page 2-4).
12. **Personality DIP Switch Settings** – this chart lists the switch settings for the operating mode of the fixture.

Obtaining and Installing the Power Cord Cap

You must obtain and install a power cord cap before you can connect the Cyberlight to a power outlet. The type of power cord cap you must obtain depends on the location in which the Cyberlight will be used; different locations (even within the same country) might have different power cord cap requirements.

Note Because of the wide variety of power cord caps used worldwide, High End Systems cannot make specific recommendations for the particular power cord cap you should use. Contact a local authority if you are unsure which type of power cord cap you need.

Important Power Cord Cap Information - U.K. Only

IMPORTANT The cores in the mains lead are colored in accordance with the following code:

- **green and yellow:** earth
- **blue:** neutral
- **brown:** live

Since the colors of the cores in the mains lead of this equipment may not correspond with the colored markings identifying the terminals in your plug, proceed as follows:



- The core which is colored green and yellow must be connected to the terminal in the plug which is marked with the letter “E” or by the earth symbol (⊕), or colored green or green and yellow.
- The core which is colored blue must be connected to the terminal which is marked with the letter “N” or colored black.
- The core which is colored brown must be connected to the terminal which is marked with the letter “L” or colored red.



Class 1 equipment: THIS EQUIPMENT MUST BE EARTHED.

VIGTIG FIKKER HEDS INFORMATION - DANMARK

ADVARSEI: RESKYTTEKSE MOD ELEKTRISK SHOCK.

VIGTIGT!
LEDERE MED GROEN/GUL ISOLATION
MA KUN TILSLUTTES EN KLEMME MAERKET
 ELLER 

Setting the Cyberlight[®] Fixture Voltage

The Cyberlight fixture voltage is factory-set to customer requirements. Normally, the factory setting is correct for your typical use. However, if you change venues and need to change the fixture's input voltage, refer to the procedure in this section. (Appendix D has a listing of typical power requirements worldwide.)

By moving one wire on the power supply board you can set the input voltage to any of the following:

205 volts 50 hertz

208 volts 60 hertz

230 volts 50 hertz

230 volts 60 hertz

240 volts 50 hertz



Warning Check the voltage selection jumper before proceeding with the equipment setup! Be sure to match the voltage selection jumper to your power source prior to operating this equipment. *Do not set the voltage selection jumper with the equipment plugged in.*

Changing the Voltage Selection Jumpers

You will need: - one right angle 5/32 inch allen wrench



Warnings: (1) An unshielded MSR/MSD 1200 lamp emits ultraviolet and visible (UV-vis) radiation which could damage eyes and skin. Wear eye and hand protection when re-lamping. Never look directly at the lamp while lamp is on.



(2) Hot lamp may be an explosion hazard. Do not open for 5 minutes after switching off.

(3) Equipment surfaces may reach temperatures up to 62° C (144° F). Allow 10 minutes for cooling before handling.

(4) To avoid the risk of electric shock, turn the fixture OFF and unplug it from the power source before performing this service.

1. After allowing the fixture to cool as described above, turn the power switch OFF and unplug the fixture. Refer to the section titled “Setting the Cyberlight Power Switch” on page 1-29 for power switch settings.
2. With the fixture oriented bottom-side up, remove the center access door by sliding the two door latches inward. Lift the door *straight up*, unhook the safety chain, and set the door aside. See Figure 1-2.

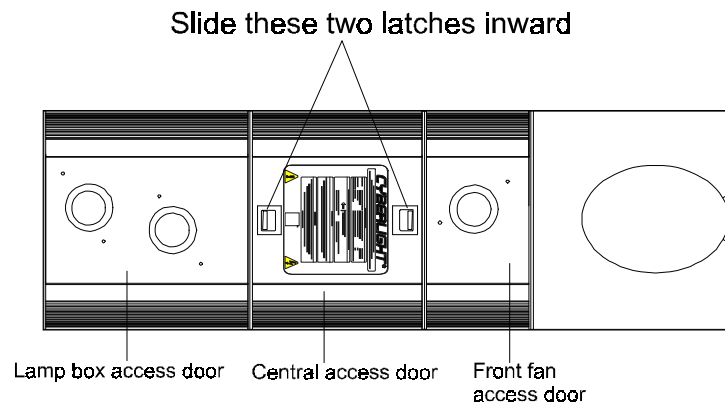

Figure 1-2. View of the bottom of the Cyberlight fixture, where the access door latches are located.

3. Remove the fixture's lamp box access door by removing six 5/32 inch allen head screws as follows:
 - Remove the four 5/32 inch allen head screws from the bottom of the rear panel as shown in Figure 1-3.

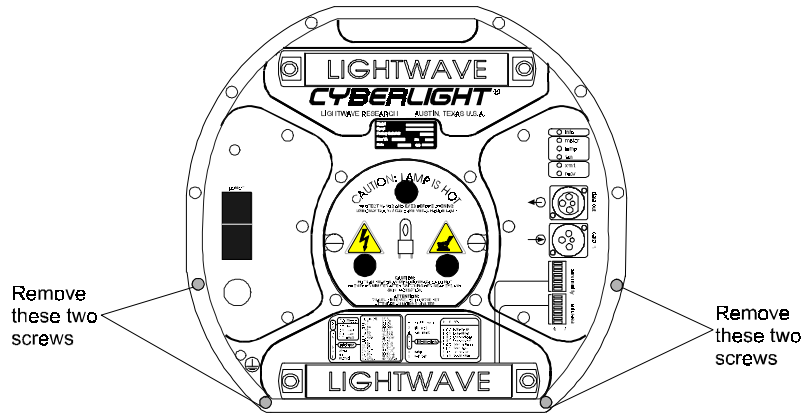

Figure 1-3. Removing the first four rear panel screws in order to access the Cyberlight voltage selection jumpers.

- Remove the last two 5/32 inch allen head screws from the color mixing plate as shown in Figure 1-4.

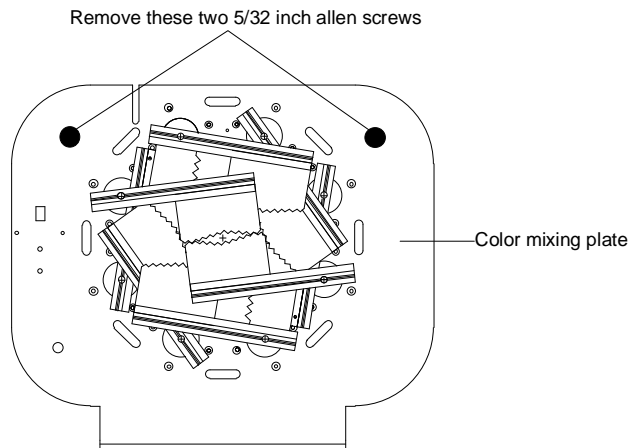

Figure 1-4. In order to remove the lamp box access door, you need to remove the last two 5/32 inch allen screws, which are located by the color mixing and dim flags.

- Carefully lift the lamp box access door from the fixture.
- CL and CX models only:* As you lift the assembly, disconnect the two fan power connectors (black and red wires) from the power supply board as shown in Figure 1-5. Set the lamp box access door aside. You now have access to the power supply board.

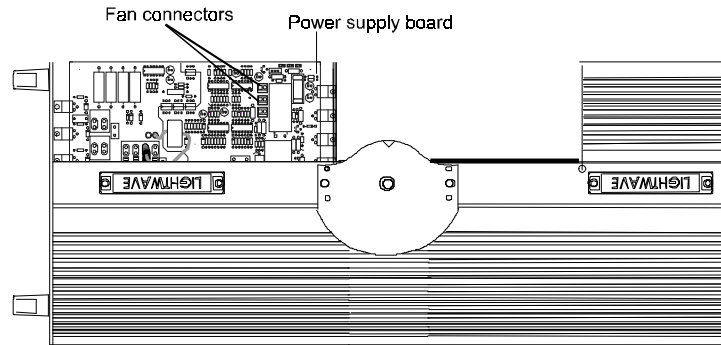

Figure 1-5. On CL and CX models, make sure you disconnect the fan power wires from the fan connectors before removing the lamp box access door.

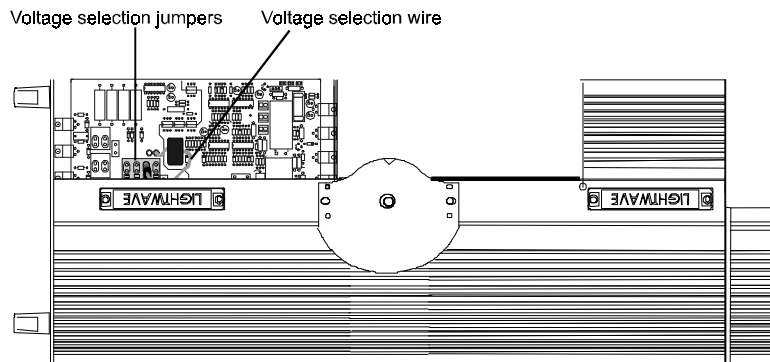

Figure 1-6. Location of the voltage selection jumpers and the voltage selection wire.

- Locate the four voltage and frequency selection tabs shown in Figure 1-7; they are on the left side of the power supply board.

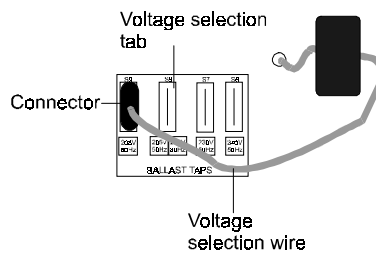

Figure 1-7. Location of the voltage selection tabs and connector.

7. Note which of the four tabs currently has the jumper wire attached. If you need to change the voltage/frequency setting, grasp the connector and pull or wiggle it to remove it from the tab. *Make sure you pull on the connector and not on the wire.*
8. Move the voltage selection wire to the desired tab and firmly press the connector onto it. If the connector has spread from use, gently squeeze it together with pliers. A loose connector will overheat and turn brown.
9. Reinstall the lamp box access door with the six screws in the reverse order in which you removed them (see Step 3 on page 1-12).
10. Connect the safety chain to the center access door and replace the door (see Step 1 on page 1-11).

Installing the Yoke

You will need: ***(The items listed below are shipped with the Cyberlight)***

- ***two 5/16 inch carriage bolts***
- ***two clamping T-handles***
- ***yoke***
- ***two 5/16 inch allen cap screws***
- ***two 9/16 inch locknuts (nut with nylon insert)***

(The items listed below are NOT shipped with the Cyberlight)

- ***5/16 inch allen wrench***
- ***9/16 inch socket wrench or 9/16 inch wrench***

1. If the fixture has been running recently, allow it to cool for at least 10 minutes. Then turn the power OFF.
2. Remove the center access door. You do not need to unlatch the safety chain.
3. Stand the fixture on its end handles.
4. Insert the carriage bolts through the star-shaped hole in the yoke and attach the clamping T-handles to the carriage bolts. The T-handles should not be very tight; you will adjust them later. Figure 1-8 shows the orientation of parts.

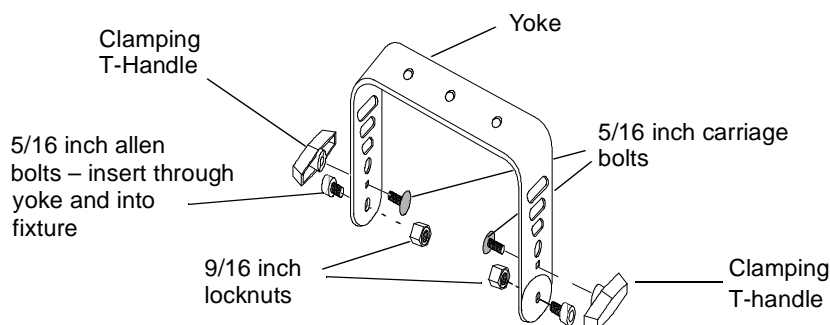

Figure 1-8. Components of the Cyberlight yoke.

5. Do both of the following when you place the yoke on Cyberlight:
 - Make sure the U-shape of the yoke is opposite the center access door, as shown in Figure 1-9.
 - Align the bottom holes on the yoke with the yoke pivot hole labeled in Figure 1-9.
6. Insert the two 5/16 inch allen bolts through the round holes in each side of the yoke, and through the holes in the side of the Cyberlight. Tighten them using your fingers or an allen wrench.
7. Place a locknut on the end of each 5/16 inch allen bolt. You can use either a 9/16 inch socket wrench or a 9/16 inch wrench to turn the nut. Tighten the nut until so you are still able to pivot the fixture.
8. Position the yoke as desired, using the deviation degree markings on the yoke for exact positioning. When you have placed the fixture correctly, firmly tighten the T-handles.

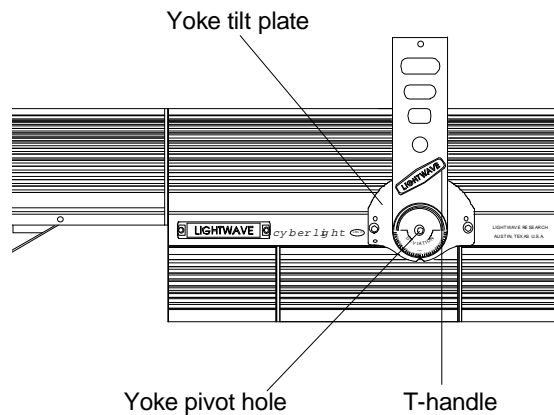

Figure 1-9. Installing the yoke on the Cyberlight fixture.

9. On the top of each yoke are three 13 mm (1/2-inch) diameter mounting holes which provide two different ways to mount the fixture. For more information, see the section titled “Mounting the Fixture” on page 2-9.

Installing or Replacing the MSR 1200 Lamp

- You will need:**
- 1200 W, G-22 Base, MSR1200 or MSD1200 Metal Halide Lamp Only
 - Protective eye wear
 - Protective gloves

Warnings (1) This equipment is designed for use with Philips® type MSR1200 or MSD1200, 1200 watt lamp only. Use of any other type lamp may be hazardous and will void the warranty.

(2) Change the lamp if it becomes damaged or thermally deformed.

(3) An unshielded MSR/MSD 1200 lamp emits ultraviolet and visible (UV-vis) radiation which could damage eyes and skin. Whenever you are working on or near an exposed MSR/MSD 1200 lamp, wear protective eye gear. Never look directly at the lamp while lamp is on.



(4) Hot lamp may be an explosion hazard. Do not open for 5 minutes after switching off. Wear eye and hand protection when re-lamping.

1. Allow the fixture to cool as described above, then power OFF the fixture and unplug it from the power source.
2. Fully back out the two lamp assembly screws shown in Figure 1-10. The screws have retaining springs that prevent them from being removed.

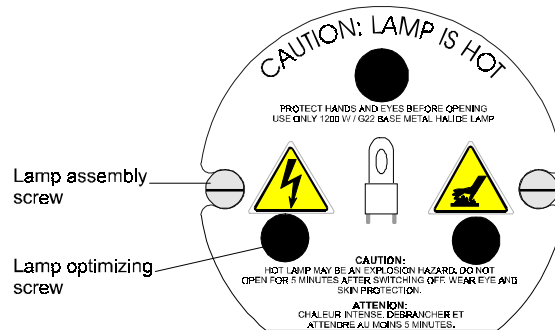

Figure 1-10. Location of lamp assembly and optimization screws.

3. Grip the assembly by the three lamp optimizing screws and pull the assembly straight out the back of the fixture. The lamp's power cord is long enough to allow you to pull the lamp assembly entirely free of the Cyberlight.
4. When the lamp assembly is free, pull the old lamp straight up and out of the assembly as shown in Figure 1-11:

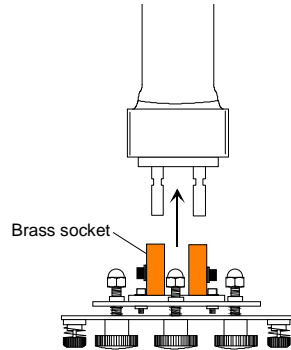

Figure 1-11. Removing the lamp from its socket.

5. *Put on your protective gloves.* Remove the plastic shell containing the new lamp. Break the seal, open the container and remove the lamp.
6. Hold onto the ceramic lamp base and gently press the two lamp base pins into the brass lamp sockets as shown in Figure 1-12. *Do not force the lamp into the socket; doing so could break the lamp.*



Cautions (1) **Avoid touching any part of your skin to the lamp's quartz envelope. Oil and residue from your fingers can create a "hot spot" on the lamp, causing premature lamp aging.**

(2) **Do not adjust the three optimization screws labeled in Figure 1-12. You will adjust these screws in a separate procedure, described in the section titled "Optimizing the Cyberlight Fixture Lamp" on page 1-18.**

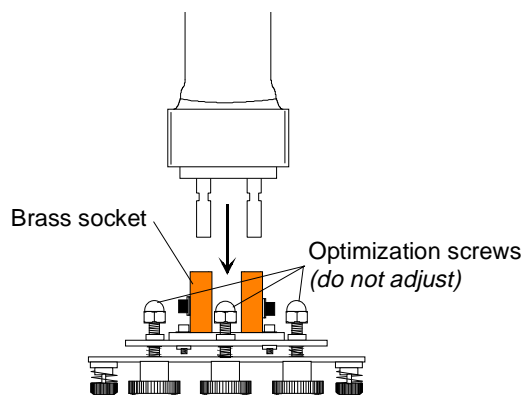
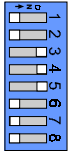

Figure 1-12. Installing the new lamp into the socket.

7. Before you insert the lamp assembly back into the fixture, clean the lamp with the alcohol wipe shipped with the lamp. Otherwise, fingerprints and other contaminants will shorten lamp life.
8. Carefully guide the lamp assembly straight back into the fixture and make sure the lamp is inserted into the reflector. Be careful not to crimp the two lamp wires as you insert the lamp assembly. Firmly tighten the two lamp assembly screws to secure the assembly to the fixture.

Resetting the Information Counter

The information counter tracks the cumulative length of time (in hours) the lamp has been on and the number of lamp *strikes* (the number of times the lamp has been illuminated). To reset the counter after changing the MSR lamp, perform the following steps:



personality

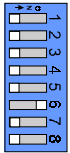

address

1. Turn the fixture power OFF (refer to Figure 1-21).
2. Set personality switches 3, 4, and 5 ON.
3. Note the current settings of all address switches, then set all address switches OFF, except for switch 6. Address switch 6 must be set ON.
4. Turn the fixture power ON (the fixture will not home).
5. Set personality switches 3, 4, 5, and address switch 6 (from Step 3) OFF.
6. Return the address switches to their previous settings.

Optimizing the Cyberlight Fixture Lamp



Caution Never operate the Cyberlight fixture without first optimizing the lamp. Damage to the fixture can occur if the lamp is misaligned.

In order to get optimal light output you need to position the lamp's arc at the focal point of the fixture's reflector (i.e., *optimize* the lamp). You can do this by following the procedure below:

1. Make sure the fixture's power switch is OFF (see the section titled "Setting the Cyberlight Power Switch" on page 1-29). Then plug the fixture's power cord into the electrical outlet.
2. Place the Cyberlight in "setup" mode by setting personality DIP switch 2 ON as shown in Figure 1-13. Make sure that all the remaining personality DIP switches are OFF.



Figure 1-13. Placing Cyberlight fixture in setup mode allows you to perform the necessary lamp optimization prior to using a newly-installed lamp.

3. Turn the fixture power ON. The fixture homes before striking the lamp. During the homing operation you will hear clattering sounds as the wheels, shutter, and mirror seek their home positions. *This is normal.* (If the lamp fails to strike, make sure personality switch 2 is set ON.)
4. Point the beam at a flat surface several feet away and make sure the beam has a round shape (not an oval) by following the suggestions below. (If a perfectly flat surface is not available, point the beam at the flattest surface you can find.)

- If the Cyberlight is already connected to a controller, bring a litho into focus. Then select the open positions on all wheels (static litho, rotating litho, color and effects). Now optimize as explained in this section. Procedural information for selecting effects can be found in the documentation provided with your controller. If you are using DMX 512 protocol to control your Cyberlight, also see Appendix A.
 - If the Cyberlight is not connected to a controller, either lay the fixture flat on its back or stand it on its end handles. Point the beam at a flat surface several feet away. Manually swivel either the mirror or the fixture to make the beam as round as you can.
5. Using the three adjusting screws (shown in Figure 1-10), adjust the beam until it is at its maximum brightness and the light level is even across the beam. If you cannot obtain an even brightness across the entire beam, try to obtain an even brightness across the brightest (hot spot) point of light near the center of the beam.
- Hint:** If you have difficulty optimizing the lamp or run out of adjustment on one of the adjustment screws, turn all three screws fully out and start over.
6. After you have optimized the lamp, set personality switch 2 OFF; the shutter closes. The lamp will turn off in a few minutes. Wait until the fans have shut off before turning the fixture OFF.

Installing SV Color Wheel Dichroic Filters

This section applies to the SV model only. The SV ships with a color wheel configured identically to the CL, plus two additional color wheel dichroic filters you can use in place of the factory-installed dichroic filters. The two additional filters are described below:

- The CTO color correction dichroic filter is salmon-colored and can be used to color-correct the SV to a 2950° K (tungsten) color temperature to match tungsten-filament lighting fixtures.
- The homogenizing frost filter helps optimize the color mixing system by making the light color and intensity even across the entire beam.

High End Systems recommends that you substitute the CTO color corrector for the CL color corrector and the homogenizing frost filter for the aqua filter.



Please heed the following precautions when handling and using these filters:

- **Avoid touching the center of the glass. Handle the edge of the glass when removing or installing the filters. If possible, wear cloth gloves when inserting and removing filters from the color wheel.**
- **If necessary, clean the filters with a mild glass cleaner and a soft cloth.**

1. Remove the fixture's center access door as shown in Figure 1-14.

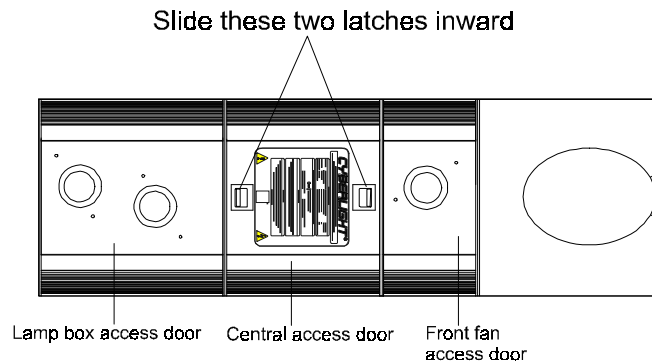

Figure 1-14. Removing the center access door.

2. Rotate the color wheel until the dichroic you wish to replace is in a position for easy access. Figure 1-15 shows the location of the color wheel. Figure 1-16 shows the position of the dichroics in the color wheel.

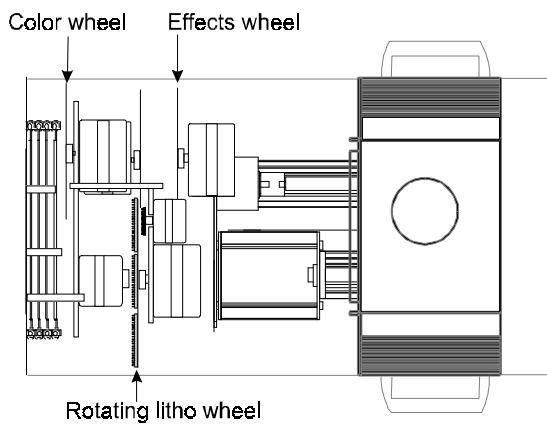

Figure 1-15. The color wheel is located between the effects wheel and the color mixing flags, opposite the rotating litho wheel.

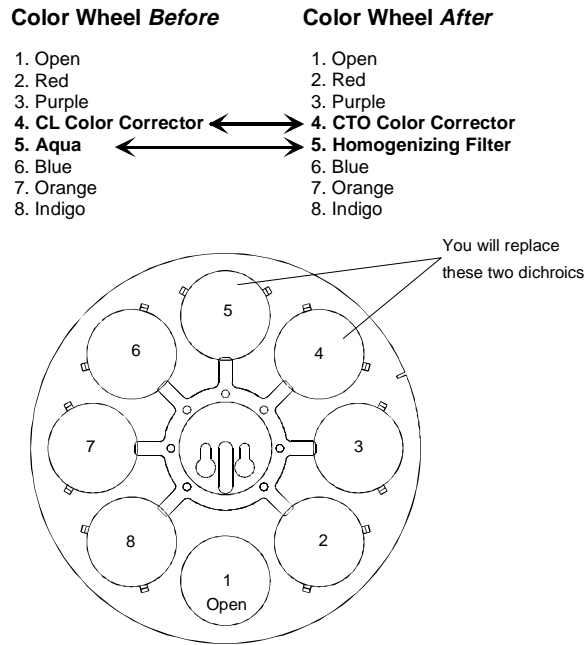

Figure 1-16. High End Systems recommends you replace the CL color correction filter (at position 4) with the salmon-colored CTO correction filter, and the aqua filter (at position 5) with the homogenizing frost filter.

Note Wheel positions are numbered starting at the open hole (position 1). The other seven positions are numbered counter-clockwise from position 1 when you are facing the color wheel toward the lamp.

3. Push the filter you wish to replace toward the center of the wheel to free it from the two wheel tabs as shown in Figure 1-17:

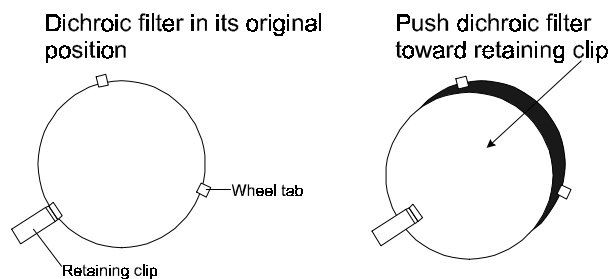

Figure 1-17. Push the dichroic filter toward the large retaining tab to free it from the wheel clips.

4. Once the dichroic is free of the two wheel tabs, pull it out of the wheel. Place the dichroic you just removed in a safe place where it will not get scratched.
5. Orient the CTO color corrector so the coated side is facing the lamp, and with the glass side facing away from the lamp as shown in Figure 1-18. (The smoky-looking homogenizing frost

filter can be installed with either side facing the lamp.)

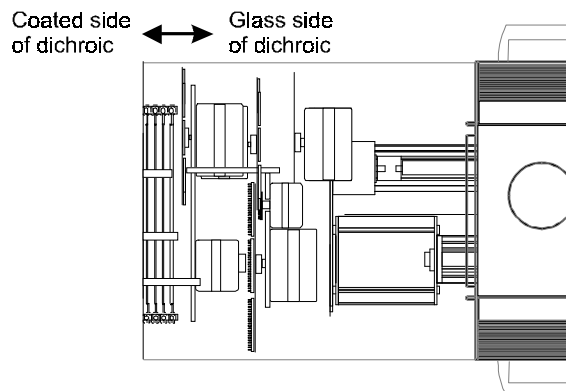

Figure 1-18. Orient the coated side of the dichroic toward the lamp and the uncoated side toward the static litho wheel.



Caution Be careful not to allow the filters to contact other objects during installation. Doing so could scratch them.

6. Push the new filter into the large retaining clip on the wheel, then pull it up so it fits under the wheel tabs.

Setting the Personality DIP Switches

There are two sets of DIP switches located on the rear panel of the Cyberlight fixture: personality (the top set) and DMX address (the bottom set). Refer back to Figure 1-1 if you are not sure of the location of these switches.

The personality switches (shown in Figure 1-19) determine the fixture's operating mode. You can use these switches for testing, setup, and for control of specialized parameters. Setting all the switches OFF is the normal operating mode when using the fixture with a Lightwave Research (LWR) protocol controller, such as the Status Cue system or the Cyberlight LCD controller. Note that a switch is ON when it is adjacent to the switch number and OFF when it is away from the switch number.

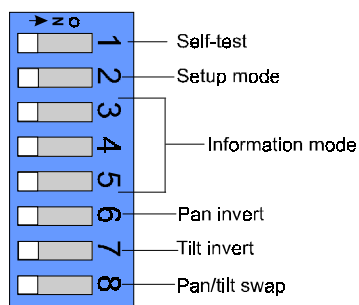

Figure 1-19. The personality switches.

Personality Switch Setting Descriptions

All Switches Off: Normal Mode

When all switches are OFF, the fixture must be controlled by Lightwave Research (LWR) control protocol. For more about LWR and DMX 512 control protocols, see Chapter 2.

Switch 1: Self-Test

Switch 1 On – Setting switch 1 ON starts an internal self-diagnostic routine which verifies the major functions of the fixture.

After setting switch 1 to ON, the fixture homes (you will hear gears turning and clacking). Except for the homing procedure, which is performed only once, the self-test repeats until you set switch 1 back OFF.

Note Setting switch 1 ON overrides any controller that might be attached to the fixture. You must set switch 1 back to OFF before attaching a controller to the fixture.

A controller is not required for the self-test. However, if you do have a controller you might want to verify fixture functionality under either DMX or LWR control. If you are using the Status Cue system to control the Cyberlight, refer to its documentation for the procedure. If you are using another controller, refer to the documentation shipped with the controller and also to Appendix A.

Switch 1 Off – This is the normal operating mode. During normal operation the motor, fan, and lamp LEDs on the rear panel are ON (see Table 1-3 for a description of rear panel LEDs).

Switch 2: Setup Mode

Switch 2 On – Setting switch 2 ON causes the lamp to strike. This allows you to adjust (optimize) the lamp without connecting the fixture to a controller. It is very important to optimize the lamp before operating the fixture with a newly-installed lamp. Failure to do so could result in damage to the fixture. (See “Optimizing the Cyberlight Fixture Lamp” on page 1-18.)

Note Setting switch 2 ON overrides any controller that might be attached to the fixture. You must set switch 2 back to OFF before attaching a controller to the fixture.

Switch 2 Off – Normal operation.

Locating the Information LED

Before describing the remainder of the Cyberlight switches, you need to know the location of the information LED on the rear panel of the fixture. Figure 1-20 shows the location of this LED:

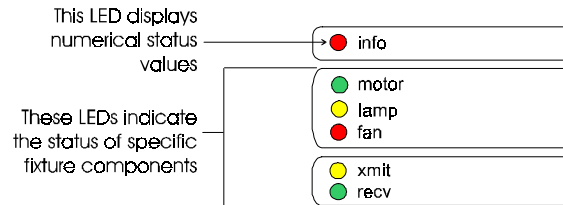

Figure 1-20. The Cyberlight rear panel LEDs give you information about the Cyberlight fixture's lamp, fixture voltage, operating temperature, data transmission and reception, and other factors.

Switches 3, 4, and 5: Information Mode

Personality switches 3, 4, and 5 control what the “info” LED displays. For example, setting switches 3, 4, and 5 all OFF causes the “info” LED to display the number of hours the lamp has been on. The other information controlled by personality switches 3, 4, and 5 is shown in Table 1-2:

Table 1-2: Cyberlight Information Mode

Set Switches			To Read this Information
3	4	5	
Off	Off	Off	Lamp Hours
Off	Off	On	Lamp Strikes
Off	On	Off	Lamp Voltage
Off	On	On	Lamp Current
On	Off	Off	Fixture Voltage
On	Off	On	Fixture Temperature
On	On	Off	<i>Reserved</i>
On	On	On	Fixture Version Number

A detailed description of the information displayed in Table 1-2 is shown below:

Lamp Hours [off-off-off] – The total number of hours the lamp has been on since the counter was reset.

Lamp Strikes [off-off-on] – The total number of lamp strikes.

Lamp Voltage [off-on-off] – The lamp voltage value at the moment of this sample.

Lamp Current [off-on-off] – The lamp current value at the moment of this sample.

Fixture Voltage [on-off-off] – The fixture voltage value at the moment of this sample.

Fixture Temperature [on-off-on] – The fixture temperature (in °C) at the moment of this sample.

Reserved [on-on-off] – These switches are reserved for future expansion.

Version number [on-on-on] – The fixture's software version number.

Interpreting the Information LED

The “info” LED on the Cyberlight fixture’s rear panel indicates numerical values by blinking. Individual digits in a number are separated by a short pause. Iterations of the same number are separated by a long pause.

The value that the info LED represents is determined by personality switches 3 through 5. Once you set the switches as shown in Table 1-2 on page 1-24, the same value is repeated until you change the switch settings.

Example #1: The number 3 would appear as shown below:

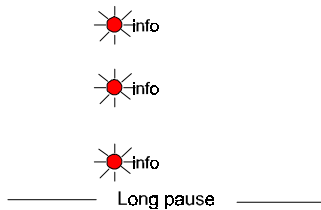

Example #2: The number 230 would appear as shown below:

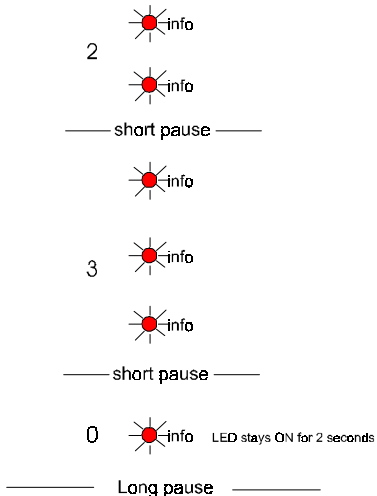

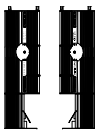

Switch 6: Pan Invert

Switch 6 inverts the pan motor, which allows two opposing fixtures to respond to joystick control in the same direction.

Switch 6 On – Reverses pan motor movement.

Switch 6 Off – This is the normal operating mode. The pan motor moves in its normal direction.

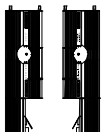

Switch 7: Tilt Invert

Switch 7 inverts the tilt motor, which allows two opposing or upside down fixtures to respond to joystick control in the same direction.

Switch 7 On – Reverses tilt motor movement.

Switch 7 Off – This is the normal operating mode. The tilt motor moves in its normal direction.



Switch 8: Pan/Tilt Swap



Switch 8 swaps the pan motor and tilt motor operation, which allows perpendicularly-hung fixtures to respond to joystick control in the same direction.

Switch 8 On – Swaps the pan motor and tilt motor movement.

Switch 8 Off – This is the normal operating mode. The pan and tilt motors move in their normal directions.

Rear Panel LED Indicators

Table 1-3 lists the meanings of the information and status LEDs located on Cyberlight fixture's rear panel. Refer back to Figure 1-1 earlier in this chapter for the location of the rear panel LEDs.

Table 1-3: Description of Cyberlight Rear Panel LEDs

LED Name	LED Color	Description
info	red (blinks)	Provides fixture status information. See "Switches 3, 4, and 5: Information Mode" on page 1-24.
motor	green	Normal.
	off	Check power supply board fuses as shown in "Replacing Power Supply Fuses" on page 3-15.
lamp	steady yellow	Normal.
	flashing yellow (1 flash/sec)	Lamp failed to strike. See "Troubleshooting" on page 2-12.
	rapid flashing	Over-temp condition. See "Troubleshooting" on page 2-12.
	off	Timed out from loss of data.
fan	red	Normal.
	off	Fans have automatically shut off.
xmit	yellow	The fixture is transmitting data back to a controller.
	off	No data is being transmitted.
recv	green	The fixture is receiving data from a controller.
	off	No data is being received.

If you believe that the LEDs are indicating a problem situation, or if you are experiencing problems with your fixture, see the section titled "Troubleshooting" on page 2-12.

Putting the Fixture Into Use

Before putting the Cyberlight fixture into use, you need to do the following:

- Make sure the Cyberlight power cord cap is wired correctly.
- Make sure the Cyberlight is set for the correct voltage. Appendix D contains a listing of typical voltages worldwide. *You should always verify the proper voltage with a local authority in your venue.*
- Make sure you configured the fixture properly as described in this chapter.
- If you are connecting the fixture to a controller, see Chapter 2. If you are controlling the Cyberlight with DMX 512 protocol, also see Appendix A (for DMX 512 control).
- See the section titled “Mounting the Fixture” on page 2-9.
- Heed all of the warnings below:



WARNINGS:

- **Do not mount on a flammable surface.**
- **Maintain minimum distance of 1.0 meter (3.28 feet) from combustible materials.**
- **Observe minimum distance to lighted objects of 1.0 meter (3.28 feet).**
- **This equipment for connection to branch circuit having a maximum overload protection of 20 A.**
- **Equipment suitable for dry locations only. Do not expose this equipment to rain or moisture.**
- **Refer servicing to qualified personnel; no user serviceable parts inside.**
- **Class I Equipment - this fixture employs a grounded type receptacle and is not intended for connection to a two wire, ungrounded source of supply.**
- **Heed all other Cautions and Warnings in this manual and printed on fixture labels.**



Setting the Cyberlight Power Switch

It is very important that you turn the Cyberlight power switch OFF before performing certain procedures. Figure 1-21 shows the power switch in its ON and OFF positions:

1

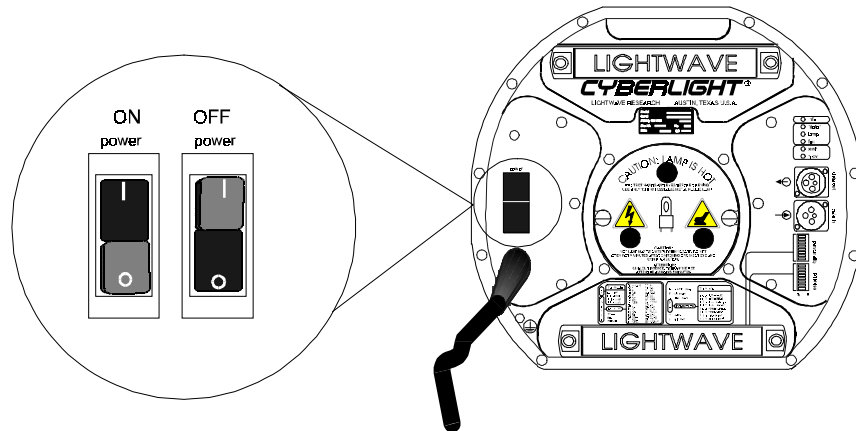

Figure 1-21. Setting the Cyberlight power switch to the ON and OFF positions.



- Warnings**
- (1) This equipment for connection to branch circuit having a maximum overload protection of 20 A.
 - (2) Class I Equipment—This fixture employs a grounded type receptacle and is not intended for connection to a two wire, ungrounded source of supply.

Where to Go From Here

The following topics are covered in the remainder of this manual:

- **Chapter 2:** Using your Cyberlight. Covers the differences between DMX 512 and LWR control protocols; implementing LWR protocol; linking fixtures to the controller; mounting the fixture; and troubleshooting suggestions.
- **Chapter 3:** Servicing your Cyberlight. Shows how to perform routine cleaning on mirrors, motors and lenses; replacing power supply fuses; replacing dichroics or lithos; adjusting the CX mechanical zoom lens; adjusting the mirror head deviation; and adjusting the yoke deviation.
- **Appendix A:** DMX control of Cyberlight. Explains the three DMX modes and how to use them. Also shows the relationship between the Cyberlight fixture number and the DMX address range it uses.
- **Appendix B:** Cyberlight mirror movement times. A table that correlates speed numbers to mirror movement times, in units of seconds.
- **Appendix C:** Factory-installed wheels. Shows the factory-installed options for the effects wheel, color wheel, static litho wheel and rotating litho wheel for all three Cyberlight models.
- **Appendix D:** Typical voltages worldwide. A table of typical voltage/frequency settings from around the world, based on High End Systems' experience.
- **Appendix E:** Important safety information. Multi-lingual warnings you must observe whenever operating the Cyberlight fixture.
- **Glossary**
- **Index**

Chapter 2

Using Your Cyberlight®

Choosing DMX 512 or LWR Protocol.....	2-2
What is DMX 512 Protocol?	2-2
What is LWR Protocol?	2-2
Controlling Multiple High End Systems Fixtures on the Same Link.....	2-3
Implementing DMX/LWR Control	2-3
Setting the Address DIP Switches	2-4
Address Switch Descriptions	2-4
Switches 1 through 6: Set LWR Protocol Fixture Number.....	2-4
Switches 7 and 8: Protocol Mode.....	2-5
Obtaining Cabling and Terminators	2-6
Constructing Cabling.....	2-6
Terminators	2-7
Linking the Fixtures to the Controller	2-8
Mounting the Fixture	2-9
Standing the Fixture on its End Handles	2-9
Mounting the Fixture on a Truss or Other Support System	2-10
Troubleshooting.....	2-12
Checking and Correcting Wheel Clearances.....	2-18

Choosing DMX 512 or LWR Protocol

Before connecting your Cyberlight to a controller, you need to understand the difference between DMX 512 and Lightwave Research (LWR) control protocols.

What is DMX 512 Protocol?

DMX 512 is an industry-standard method of controlling lighting fixtures and other devices (such as lasers and hazers). Developed by the United States Institute of Theatre Technology (USITT), DMX 512 is supported by leading entertainment industry equipment manufacturers, such as High End Systems.

DMX 512 (*D* for *digital*, *MX* for *multiplex* and *512* is the number of channels per link) is a reliable, efficient and well-understood control protocol. Its strength lies in its ability to control a large number of different types of devices made by various vendors on the same link using any DMX-compatible controller.

High End Systems recommends setting the Cyberlight for DMX 512 protocol (mode 2) for the following reasons:

- The Cyberlight dynamically responds to both DMX 512 and LWR protocols. The fixture will switch to LWR protocol for software uploads, then switch back to DMX 512 control with no user intervention. (LWR protocol is the only way to perform software uploads for the Cyberlight using either a Link Card or the Cyberlight Upload Module.)
- DMX mode 2 affords the most features and best resolution of all three DMX modes. (See Appendix A for more detailed information.)

What is LWR Protocol?

LWR protocol is another way to control fixtures, and is the protocol used for Cyberlight software uploads using either a Link Card or the Cyberlight Upload Module. However, LWR protocol can be used to control *only* Cyberlight fixtures, Intellabeam[®] automated luminaires, Emulator[®] laser simulators and Trackspot[®] automated luminaires with a controller that supports LWR protocol. (Other vendors besides High End Systems have controllers that support LWR protocol. Consult the documentation provided with your controller for information about protocol support.)

Setting a Cyberlight for LWR protocol would be a good idea if the following are true:

- You have only Cyberlight fixtures on a link and are controlling them with the Cyberlight LCD controller, the Status Cue system or another controller that supports the LWR protocol.
- You have only Cyberlight fixtures, Trackspot fixtures and/or Intellabeam fixtures attached to a link and are controlling them with the Status Cue system. You cannot have any other vendor's equipment on the same link.

Note At the time of this writing, you cannot perform a Cyberlight software upload using another vendor's controller, even if the controller supports LWR control protocol.

Controlling Multiple High End Systems Fixtures on the Same Link

High End Systems recommends, if possible, that you do not mix Cyberlight fixtures with other High End Systems equipment on the same link. There are two reasons for making this recommendation:

- Cyberlight fixtures have the largest number and variety of effects to control; therefore, putting only Cyberlight fixtures on a link saves you the trouble of having to remember which fixtures respond to which commands.
- Intellabeam fixtures, Emulator fixtures and AF1000 fixtures will stop software uploads to Cyberlight fixtures farther down the link. Therefore, if you *are* going to mix Cyberlight fixtures with Intellabeam fixtures and AF1000 fixtures on the same link, make sure you put all of the Intellabeam fixtures and AF1000 fixtures *after* all of the Cyberlight fixtures.

Implementing DMX/LWR Control

Once you have decided whether to control your Cyberlight fixture using DMX 512 or LWR protocol, the procedure for connecting the fixtures to a controller is exactly the same. You need to follow the four basic steps listed below. Each step will be explained in greater detail during the remainder of this chapter.

Note Please consult the documentation provided with your controller for controller-specific information not covered in the remainder of this chapter.

- **Set the Cyberlight address DIP switches:** Select either LWR or DMX protocol and other options. This is covered in the section titled “Setting the Address DIP Switches” on page 2-4.
- **Obtain cabling and terminators:** Obtain the right kind of cabling and obtain or build a terminator for each link. This is covered in the section titled “Obtaining Cabling and Terminators” on page 2-6.
- **Link the fixtures to the controller:** Use XLR data-grade cable to link fixtures to the controller and be sure to terminate the last device in the link. This is covered in the section titled “Linking the Fixtures to the Controller” on page 2-8.
- **Mount the fixture:** Plan your installation and mount the fixture. This is covered in the section titled “Mounting the Fixture” on page 2-9.

Setting the Address DIP Switches

The previous sections in this chapter have helped you decide whether to control your Cyberlight using DMX 512 protocol or LWR protocol. This section explains how to implement that decision by selecting the protocol and by selecting a fixture number.

The eight DMX address DIP switches set the following options:

- Whether the Cyberlight will be controlled using DMX 512 protocol or LWR protocol.
- If you select DMX 512 protocol, you first need to determine which DMX mode you wish to use, then set the fixture number. See Appendix A for a complete description of these options.
- If you select LWR protocol, you need to set the fixture number. This is covered in the section titled “Switches 1 through 6: Set LWR Protocol Fixture Number”.

Address Switch Descriptions

Figure 2-1 below shows a functional breakdown of the address DIP switches:

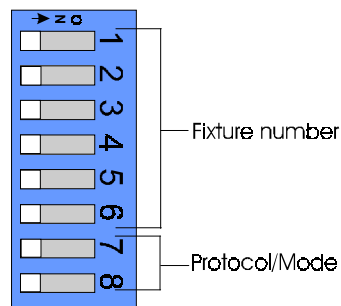

Figure 2-1. The address switch block allows you to select the control protocol (DMX 1, DMX 2, DMX 3, or LWR) and the fixture number.

Switches 1 through 6: Set LWR Protocol Fixture Number

If you are using LWR protocol to control your Cyberlight, these switches set the fixture number. Refer to Table 2-2 for switch settings. (If you are controlling your Cyberlight using DMX 512 protocol, refer to Appendix A.)

You need to assign a unique fixture number to each Cyberlight you wish to respond independently to control commands. Multiple fixtures can be assigned the same address if you wish them all to respond to control commands in the same way.

For example, suppose you have 12 Cyberlight fixtures on one link. You want six of them to operate independently of each other and the other six to operate in exactly the same way. You need to assign each of the six independently-operating Cyberlight fixtures a unique fixture number, but you can assign a single fixture number to the other six, for a total of seven fixture numbers.

Note A unique fixture number is required for each Cyberlight for software uploads.

Switches 7 and 8: Protocol Mode

Use these switches to define the communication protocol between the fixture and the controller. By default, switches 7 and 8 are both set OFF, which enables the use of Lightwave Research (LWR) protocol for fixture control. This means you *must* use a controller that supports LWR protocol. The Status Cue system and the Cyberlight LCD controller (both manufactured by High End Systems) support LWR protocol. In addition, other vendors have controllers that support LWR; consult the documentation provided with your controller for more information.

2

Table 2-1: Protocol Mode Switch Settings

Switches 7 and 8: 7 8	Mode
off off	LWR
off on	DMX 1
on off	DMX 2
on on	DMX 3

Table 2-2: Cyberlight Fixture Number Settings (LWR Protocol)

For This Fixture Number	Set These DIP Switches ON	For This Fixture Number	Set These DIP Switches ON
01	none	17	5
02	1	18	1 and 5
03	2	19	2 and 5
04	1 and 2	20	1, 2, and 5
05	3	21	3 and 5
06	1 and 3	22	1, 3, and 5
07	2 and 3	23	2, 3, and 5
08	1, 2, and 3	24	1, 2, 3, and 5
09	4	25	4 and 5
10	1 and 4	26	1, 4, and 5
11	2 and 4	27	2, 4, and 5
12	1, 2, and 4	28	1, 2, 4, and 5
13	3 and 4	29	3, 4, and 5
14	1, 3, and 4	30	1, 3, 4, and 5
15	2, 3, and 4	31	2, 3, 4, and 5
16	1, 2, 3, and 4	32	1, 2, 3, 4, and 5

Obtaining Cabling and Terminators

There are two main types of cabling you can use: microphone cable and data-grade cable. Although pin-compatible microphone cable is suitable for small-scale designs, data cable is recommended, especially for longer cable runs. Data cable is designed to carry a higher-quality signal with less susceptibility to electromagnetic interference.

The cable you use should have the characteristics listed below:

- 2-conductor twisted pair plus a shield
- maximum capacitance between conductors - 30 pF/ft.
- maximum capacitance between conductor and shield - 55 pF/ft.
- maximum resistance of 20 Ω /1000 ft.
- nominal impedance 100–140 Ω
- 22–24 AWG with insulation having a dielectric rating of 300 volts or higher

For example, Belden 9841 data-grade cabling meets specifications for EIA RS-485 applications and is highly recommended for use with Cyberlight.

Constructing Cabling

Follow the instructions in this section if you need to construct cabling. You should construct cables using shielded, two-conductor cable with a male 3-pin XLR connector at one end and a female 3-pin XLR connector on the other end. Pinouts for both male and female XLR connectors are shown in Figure 2-2.

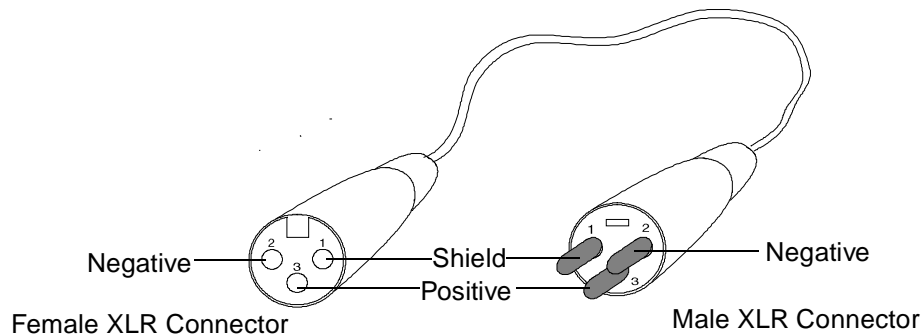

Figure 2-2. Properly-constructed data cable.

You should test each cable with a voltage/ohm meter (VOM) to verify correct polarity and to make sure that the negative and positive pins are not grounded or shorted to the shield or to each other. Also, make sure that pin 1 is shielded.

Table 2-3: XLR Cable Pinouts

Pin 1 is the shield
Pin 2 is the data compliment (negative)
Pin 3 is the data true (positive)



Caution Do not use the ground lug on the XLR connectors. Do not connect the shield to ground or allow contact to ground. Grounding the shield could cause a ground loop and/or erratic behavior.

Terminators

The last device on each link must have a 120 ohm, 1/4 watt (minimum) terminator attached to its Data Out connector. (This is true for both DMX 512 protocol or LWR protocol.) Two terminators are shipped with each link card (supplied with the Status Cue system).

You can construct terminators by following the instructions below:

1. Obtain a male XLR connector.
2. Disassemble the connector.
3. Solder a 120 ohm resistor, minimum of 1/4 watt, between pins 2 and 3.
4. Reassemble the XLR connector.
5. Install the terminator in the Data Out port of the last device in the link.

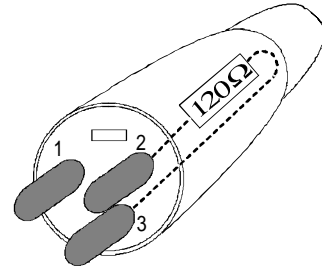

Figure 2-3. Constructing a data cable terminator.

Linking the Fixtures to the Controller

Starting with the controller, link fixtures using the procedure below. Refer also to Figure 2-4.

1. Start with the controller. Consult the documentation provided with the controller for the procedure to connect XLR cable to its Data Out connector.
2. Connect the female end of the XLR cable from the controller to the first Cyberlight fixture's male Data In connector.
3. Connect the male end of another XLR cable to the first Cyberlight fixture's female Data Out connector.
4. Continue connecting the Data Out connector from one Cyberlight to the Data In connector to the next Cyberlight until you have linked all of the Cyberlight fixtures.
5. Connect other devices to the Cyberlight fixtures as desired, using the instructions in the documentation provided with those devices.
6. Place a male 120 ohm terminator on the female Data Out connector of the last device in the link. (This is true for both DMX 512 protocol or LWR protocol.) The procedure for making a terminator can be found in the section titled "Terminators" on page 2-7.

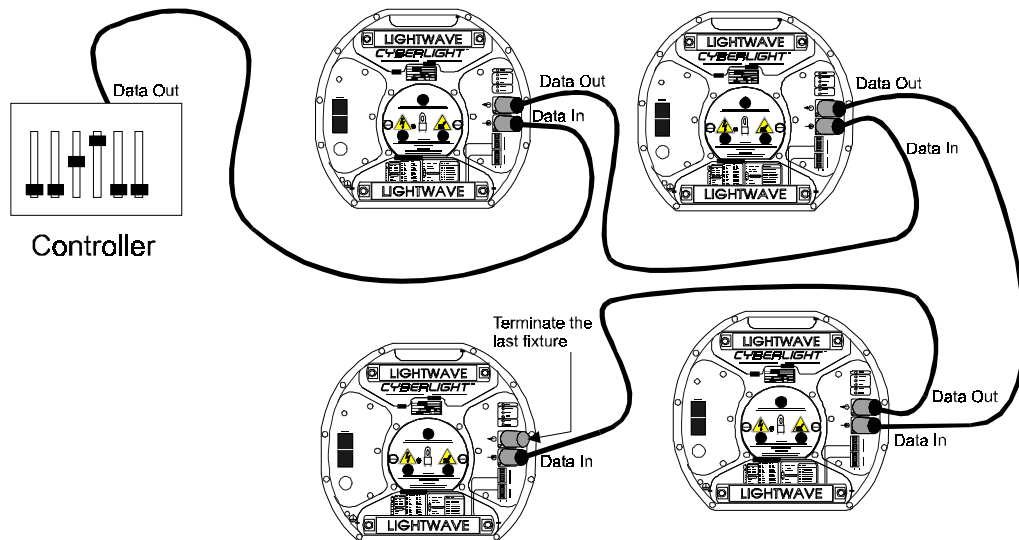

Figure 2-4. Make sure you connect the Data Out connector from the previous Cyberlight to the Data In connector of the next Cyberlight. Also, you must terminate the Data Out connector of the last device in the link (whether the last device is a Cyberlight or something else).

Mounting the Fixture

Cyberlight is designed to be mounted in any orientation; you can even stand the fixture on its end handles. However you wish to mount the fixture, you must follow the precautions and suggestions below:

- Verify the input voltage you are using matches the Cyberlight fixture's voltage selection jumpers (see the section titled "Electrical Specifications" on page 1-4 and "Changing the Voltage Selection Jumpers" on page 1-11).
- Heed the cautions and warnings below to guard against personal injury and damage to the fixture.



Cautions (1) This equipment for connection to branch circuit having a maximum overload protection of 20 A.

(2) Class I Equipment - This fixture employs a grounded type receptacle and is not intended for connection to a two wire, ungrounded source of supply.

(3) Mount the fixtures and controllers in a location that is away from direct heat and protected from moisture. Do not mount on a flammable surface.

(4) Maintain minimum distance of 1.0 meter (3.28 feet) from combustible materials. Observe minimum distance to lighted objects of 1.0 meter (3.28 feet).

Standing the Fixture on its End Handles

The Cyberlight end handles are designed to support the weight of the fixture; however, make sure you observe the following guidelines:

- The fixture must be located away from moving objects that could strike it and cause it to become unbalanced.
- The fixture must be mounted on a sturdy, stable surface.
- If the surface is other than floor height, make sure you use safety cables as described in the next section.

Mounting the Fixture on a Truss or Other Support System

If you are mounting the fixture on a truss or another type of support, do all of the following:

- Verify the truss or support will handle the weight of all the devices you are mounting. Cyberlight fixture weights are listed in the section titled “Physical Specifications” on page 1-3.
- The use of user-supplied safety cable is strongly recommended. You must supply your own safety cable and you must verify the cable is capable of supporting the weight of the fixture as listed in the section titled “Physical Specifications” on page 1-3. You can order galvanized safety cables from your High End Systems dealer/distributor (part number 12040001). Also see Figure 2-6 on page 2-11.
- You must supply your own clamps to attach the fixture to the support. You can attach one or two clamps to the Cyberlight yoke. Verify that the clamp(s) you use are capable of supporting the weight of the fixture as listed in the section titled “Physical Specifications” on page 1-3. You can order deluxe C-clamps for a two-inch truss from your High End Systems dealer/distributor (part number 55000004). Also see Figure 2-5 on page 2-11.
- Make sure the fixture *cannot* be rotated all the way around (360°). (Using two clamps is a good way to do this.) Allowing the fixture to rotate 360° could loosen the clamp mounting bolts.

Note Because of the variety of conceivable lighting designs, you should consider the procedure below as a *suggested guideline* only. High End Systems cannot make specific recommendations for your particular lighting design or venue.

Suggested mounting procedure:

1. You should use three people to mount each Cyberlight fixture: two people to hold the fixture while it is being secured in place, and one person to secure the fixture to its support and to attach clamps and safety cables.
2. Always stand on a firm, stable surface. The fixture should be at a height where you can comfortably work on it, and should also be resting on a stable surface. *Do not try to hold up the fixture yourself while you are working on it;* as Step 1 suggests, the ideal method is to have a crew of three people to install the fixture.
3. Attach a suitable clamp through one of the holes on top of the Cyberlight fixture yoke. If you are attaching one clamp, use the middle hole on the yoke. If you are attaching two clamps (as shown in Figure 2-5), attach one clamp to each of the holes on either side of the center hole. *Use locking washers when attaching the clamp to the yoke.*

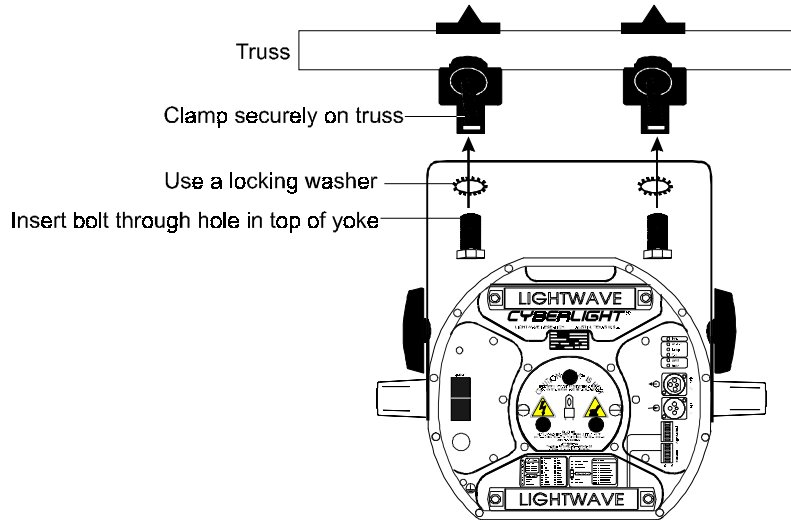

Figure 2-5. Attaching two C-clamps to the Cyberlight yoke.

4. Tighten the clamps firmly to the Cyberlight yoke and to the support.
5. Loop one or more suitable safety cables around the support and around the top of the Cyberlight yoke, as shown in Figure 2-6.

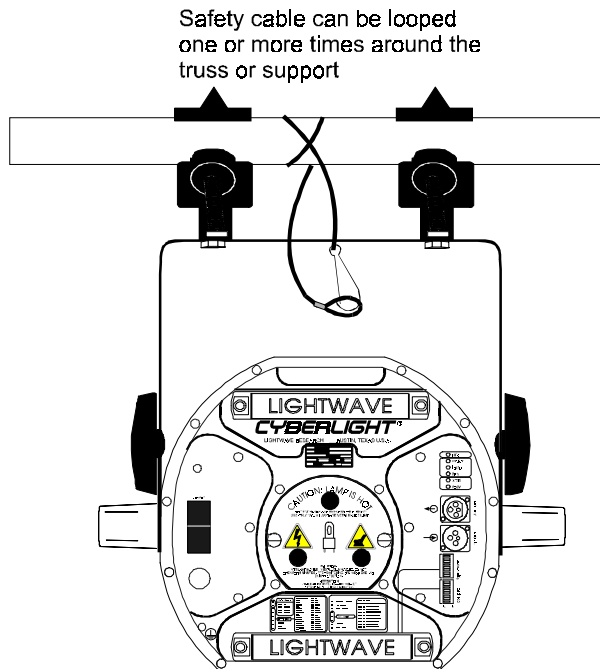

Figure 2-6. Always use suitable safety cables when hanging a Cyberlight from a truss or any other support system. The safety cable can be looped around the support and the Cyberlight yoke once or twice; loop it twice if this will help prevent the fixture from rotating, thus possibly loosening the clamp mounting bolt.

Troubleshooting

This section lists typical symptoms and solutions for problems you might encounter when using your Cyberlight. If you need additional help, or if the problem you are experiencing is not listed here, contact your dealer/distributor or High End Systems Customer Service in one of the ways shown in the section titled “Getting Help” on page Intro-4.

Contents of this section:

Fixture does not work: no LEDs, fans, lamp, or other functionality	2-12
Lamp does not strike	2-13
Lamp shuts off	2-13
Fixture is not responding to control commands—“Recv” LED does not flash	2-14
Control commands pass-through only, lamp and fans work only in self-test	2-14
Dim flags close, fixture does not respond to control commands, lamp turns off, fans turn off	2-15
Motor or mirror does not move smoothly	2-15
Color wheel or static litho wheel is not centered in the beam or is in the wrong position	2-16
Lithos or dichroic filters are cracking	2-16
Color flags, iris or other components cracked or heat damaged	2-16
Fixture will not accept software upload	2-17
Low light output, fuzzy images	2-17

Fixture does not work: no LEDs, fans, lamp, or other functionality

Possible causes and solutions:

1. *Cause:* No input power.

Solutions: Do both of the following:

- a. Verify the fixture is plugged into a working power supply.
- b. Verify the integrity of the power cord and the wiring of the power cord cap.
- c. Make sure the lamp box access door is securely fastened; this engages an interlock switch which must be engaged for the fixture to power up. The location of the lamp box access door is shown in Figure 1-14 on page 1-20.

2. *Cause:* Power supply board fuse F1 has failed.

Solution: Follow the directions in the section titled “Replacing Power Supply Fuses” on page 3-15 to inspect and replace the fuse if necessary.

Lamp does not strike

Possible causes and solutions:

1. *Cause:* Bad lamp.

Solution: Replace with a new or known good lamp.

2. *Cause:* Improper voltage setting or power cord cap wiring.

Solutions: Do both of the following:

- a. Make sure the fixture is set for the same voltage as the power supply. See “Setting the Cyberlight® Fixture Voltage” on page 1-10.
 - b. Make sure the power cord cap is wired correctly. See “Obtaining and Installing the Power Cord Cap” on page 1-9.
3. *Cause:* Power supply fuse F2 has failed. (Other symptoms are: the fans won’t work and control commands fail.)

Solution: Follow the instructions in the section titled “Replacing Power Supply Fuses” on page 3-15 to inspect the fuse and replace it if necessary.

Lamp shuts off

Possible causes and solutions:

1. *Cause:* Over-temperature.

Note The fixture’s maximum operating temperature is 50° C (122° F). An over-temperature condition can be confirmed by a rapidly-flashing yellow Lamp LED. The location of rear-panel LEDs is shown in Figure 1-1 on page 1-8.

Solutions: Do all three of the following:

- a. Check for restricted air flow. Clean the fans, especially the fans in the lamp box access door. The lamp box access door is shown in Figure 1-2 on page 1-11. Instructions for cleaning the fans are shown in the section titled “Cleaning the Fans” on page 3-3.
- b. Verify fan power connectors are attached to the power supply board. See “Setting the Cyberlight® Fixture Voltage” on page 1-10 for instructions on removing the lamp box access door so you can check fan connections.
- c. Check power supply board fuse F4. Follow the instructions in the section titled “Replacing Power Supply Fuses” on page 3-15 to inspect the fuse and replace it if necessary.

2. *Cause:* Lamp socket is loose, causing arcing.

Solution: Replace the lamp socket assembly. Call your High End Systems dealer/distributor for more information.

3. *Cause:* Aging lamp.

Solution: Replace with a new or known good lamp.

Fixture is not responding to control commands—“Recv” LED does not flash

Possible causes and solutions:

1. *Cause:* Faulty XLR cable.

Solutions: Do one or both of the following:

- a. Replace XLR cables going to the fixture’s Data In and Data Out connectors with known good cables.
- b. Verify cable integrity using cable test equipment.

3. *Cause:* There is no controller attached to the link, or the controller is not generating any output.

Solution: Verify that a controller is attached to the link. Verify that the controller is generating output by sending commands to a known working device.

4. *Cause:* Power supply fuse F2 has failed. (Other symptoms are: the fans won’t work and the lamp won’t strike.)

Solution: Follow the instructions in the section titled “Replacing Power Supply Fuses” on page 3-15 to inspect the fuse and replace it if necessary.

Control commands pass-through only, lamp and fans work only in self-test

Possible cause and solution:

Cause: Power supply board fuse F3 has failed.

Solution: Follow the instructions in the section titled “Replacing Power Supply Fuses” on page 3-15 to inspect the fuse and replace it if necessary.

Dim flags close, fixture does not respond to control commands, lamp turns off, fans turn off

Possible causes and solutions:

1. *Cause:* Faulty XLR cable.

Solutions: Do one or both of the following:

- a. Replace XLR cables going to the fixture's Data In and Data Out connectors with known good cables.
 - b. Verify cable integrity using cable test equipment.
2. *Cause:* Power supply board fuse F2 has failed.

Solution: Follow the instructions in the section titled "Replacing Power Supply Fuses" on page 3-15 to inspect the fuse and replace it if necessary.

Motor or mirror does not move smoothly

Possible causes and solutions:

1. *Cause:* Faulty or exposed wiring.

Solutions: Do both of the following:

- a. Make sure there are no exposed wires leading to the motor/mirror. Exposed wires contacting the metal chassis can short the power supply to the motor/mirror.
 - b. Verify wiring integrity using electrical test equipment.
2. *Cause:* Mechanical binding.

Solutions: Do both of the following:

- a. Manually rotate all wheels (static litho, rotating litho, color and effects) and note any contact with adjacent wheels. If there is contact, see the section titled "Checking and Correcting Wheel Clearances" on page 2-18.
- b. *Static litho wheel or color wheel:* make sure the wheel is not rubbing against its sensor (the sensor is located at the bottom of the wheel against the chassis). If there is contact, see "Checking and Correcting Wheel Clearances" on page 2-18.



Warning **Contact between wheels within the Cyberlight fixture can result in damage to fixture components and to the fixture itself!**

Color wheel or static litho wheel is not centered in the beam or is in the wrong position

Possible causes and solutions:

1. *Cause:* Wheel is rubbing against its sensor.

Solution: Manually rotate the wheel and note any contact between the wheel and its sensor (the sensor is located at the bottom of the wheel against the chassis). If there is contact, see the section titled “Checking and Correcting Wheel Clearances” on page 2-18.

2. *Cause:* Sensor or homing slot is dirty.

Solution: Clean the sensor and the homing slot. See “Cleaning the Color Wheel, Static Litho Wheel, Effects Wheel and Sensors” on page 3-7.

Lithos or dichroic filters are cracking

Possible causes and solutions:

1. *Cause:* Improper installation.

Solution:

- Static lithos and color wheel dichroic filters: dichroic filters should be oriented with the coated side facing toward the lamp and the glass (uncoated) side facing away from the lamp. Lithos should be oriented with the coated side facing away from the lamp and the glass (uncoated) side facing toward the lamp.
- Rotating litho wheel lithos: see “Removing and Installing Rotating Lithos” on page 3-19.

2. *Cause:* Faulty infrared filter allowing overheating inside the fixture.

Solution: Visually inspect the infrared filter for cracks or deep scratches. The section titled “Cleaning the Infrared Filter, Reflector, Color Mixing Flags and Dim Flags” on page 3-10 shows the location of the infrared filter and how to access it.

Color flags, iris or other components cracked or heat damaged

Possible cause and solution:

Cause: Faulty infrared filter allowing overheating inside the fixture.

Solution: Visually inspect the infrared filter for cracks or deep scratches. The section titled “Cleaning the Infrared Filter, Reflector, Color Mixing Flags and Dim Flags” on page 3-10 shows the location of the infrared filter and how to access it.

Fixture will not accept software upload

Possible causes and solutions:

1. *Cause:* Incorrect addressing or configuration.

Solutions: Do both of the following:

- a. Make sure each fixture is set for a unique fixture number.
- b. Verify that all fixture numbers called for are being used.

Note The section titled “Setting the Address DIP Switches” on page 2-4 has more information about fixture addressing.

2. *Cause:* No return communication.

Solution: Make sure you bypass any data distributors. Data distributors stop the two-way communication required for software uploads. AF1000 fixtures, Intellabeam fixtures or Emulator fixtures on the same link as the Cyberlight can also prevent return communication from Cyberlight. See the section titled “Controlling Multiple High End Systems Fixtures on the Same Link” on page 2-3 for more information.

Low light output, fuzzy images

Possible causes and solutions:

1. *Cause:* Aging lamp.

Solution: Replace the lamp with a new or known good lamp.

2. *Cause:* The lamp has not been optimized.

Solution: Optimize the lamp as shown in the section titled “Optimizing the Cyberlight Fixture Lamp” on page 1-18.

3. *Cause:* Dirty optical path.

Solution: Clean all lenses, filters, lithos, the anti-reflective glass and the mirror as shown in the sections titled “Cleaning the Color Wheel, Static Litho Wheel, Effects Wheel and Sensors” on page 3-7 and “Cleaning the Infrared Filter, Reflector, Color Mixing Flags and Dim Flags” on page 3-10.

Checking and Correcting Wheel Clearances

You will need:

- ***1/16 inch right angle allen wrench***
- ***7/16 inch wrench***
- ***5/64 inch allen wrench***

Use the procedure in this section to check for clearances between wheels and their sensors, or between wheels and other objects in the Cyberlight fixture.

1. Manually turn the color wheel and effects wheel to make sure there is no contact between them and any other object.
2. If there was any contact, adjust the wheel's clearance by taking the three actions below:
 - using a 1/16 inch right angle allen wrench, loosen the two hex screws on the wheel's hub (the rotating litho wheel is shown in Figure 2-7)
 - press on the center of the wheel to move the hub until there is no longer any contact between the wheel and its sensor or any other object in the fixture
 - retighten the screws

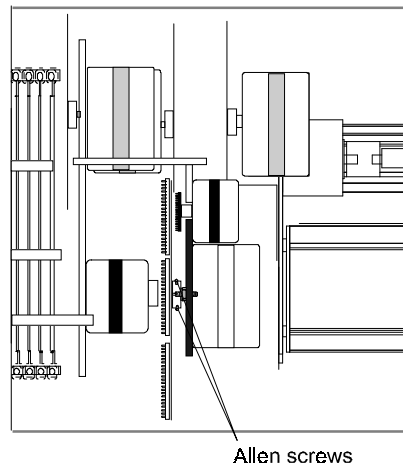

Figure 2-7. Loosening the hub screws allows you to adjust the wheel's clearance.

3. Repeat Step 2 to adjust clearances for the color wheel and effects wheel. Make note of the following:
 - If you cannot adjust the wheel to eliminate contact between the wheel and other objects or its sensor, the wheel might be warped. Follow the directions in the section titled “Cleaning the Color Wheel, Static Litho Wheel, Effects Wheel and Sensors” on page 3-7 to remove the wheel. After removing the wheel, lay it on a flat surface to determine whether it is warped. If the wheel is warped, it should be replaced. Contact Customer Service in one of the ways listed in the section titled “Getting Help” on page Intro-4 for more information.
 - The rest of the procedure applies to the rotating litho wheel only.
4. Do both of the following:
 - Gently rock the rotating litho wheel back and forth and note any contact between the rotating litho wheel and the static litho wheel.
 - Rotate a litho holder 360°, making note of any contact between it and *any* other object.
5. If you observe *any* contact between an individual rotating litho or the rotating litho wheel and any other object, adjust the rotating litho wheel hub to eliminate that contact. Loosen the two 1/16 inch allen screws shown in Figure 2-8 below and push on the center of the wheel to eliminate the contact.

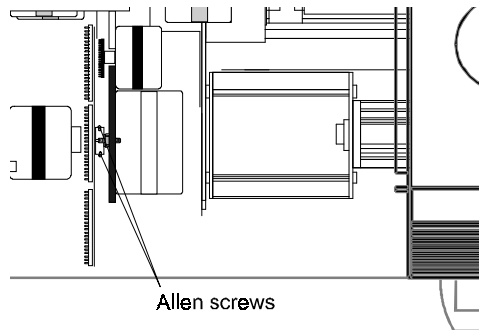

Figure 2-8. Loosen these two allen screws to adjust the rotating litho wheel.

6. Make sure the white spring plunger still makes contact with the rotating litho wheel. The location of the spring plunger is shown in Figure 2-9.

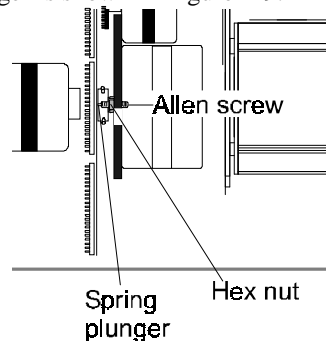

Figure 2-9. The rotating litho wheel's spring plunger must always contact the rotating litho wheel.

7. If the spring plunger *does* contact the rotating litho wheel, proceed with Step 8. Otherwise, do the following:
 - Use a 7/16 inch wrench to loosen the hex nut shown in Figure 2-9.
 - Use a 5/64 inch allen wrench to turn the allen screw shown in Figure 2-9. This allen screw moves the spring plunger in and out. Adjust the plunger so that it makes contact with the rotating litho wheel.
 - Use a 7/16 inch wrench to retighten the hex nut.
8. Repeat Steps 4 through 7 until you are sure there is no contact between either the rotating litho wheel or an individual rotating litho and any other object in the fixture.

Note You can turn the rotating litho wheel until both the wheel and the lithos are locked in place (they will not move). This is the normal “homed” position of the wheel.

Chapter 3

Servicing Your Cyberlight®

General Maintenance and Cleaning	3-2
Cleaning the Outer Surfaces.....	3-2
Cleaning the Fans	3-2
Cleaning the Internal Components.....	3-4
Removing the Center Access Door.....	3-4
Cleaning the Mirror, Lenses, Motors and Iris.....	3-4
Cleaning the Color Wheel, Static Litho Wheel, Effects Wheel and Sensors	3-7
Cleaning the Infrared Filter, Reflector, Color Mixing Flags and Dim Flags.....	3-10
Removing and Cleaning the Rotating Lithos.....	3-14
Replacing Parts.....	3-15
Replacing Power Supply Fuses.....	3-15
Removing and Installing Rotating Lithos	3-19
Removing a Litho from the Rotating Litho Wheel.....	3-19
Replacing Dichroics/Lithos in the Color Wheel or the Static Litho Wheel.....	3-22
Adjustments.....	3-23
Adjusting the Mechanical Zoom Lens (CX Only).....	3-23
Adjusting the Mirror Head Deviation	3-24
Adjusting the Yoke Deviation.....	3-26

General Maintenance and Cleaning

You should clean your Cyberlight after each lamp change to maintain performance and reliability, since dust and dirt can accumulate and cause overheating or malfunctions.



Warning Before performing any service or maintenance, make note of the following:

(1) Hot lamp may be an explosion hazard. Do not open for 5 minutes after switching off. Wear eye and hand protection when re-lamping.

(2) Equipment surfaces may reach temperatures up to 62° C (144° F). Allow 10 minutes for cooling before handling.

(3) Disconnect power before re-lamping or servicing.

After allowing the fixture to cool down and powering it off, see one of the topics listed below:

- “Cleaning the Fans” on page 3-3
- “Cleaning the Mirror, Lenses, Motors and Iris” on page 3-4
- “Cleaning the Color Wheel, Static Litho Wheel, Effects Wheel and Sensors” on page 3-7
- “Cleaning the Infrared Filter, Reflector, Color Mixing Flags and Dim Flags” on page 3-10

Cleaning the Outer Surfaces

Wipe the outer surfaces with a soft cloth or use a vacuum to remove the built-up dust and dirt.

Cleaning the Fans

If necessary to remove built-up dust and dirt from the fans, you can use a low-pressure compressed air source to clean them. You must place an object (*not your fingers!*), such as a pen or a screwdriver, into the fan fins to prevent the fans from spinning while you are blowing air into them; *allowing the fans to spin can result in severe damage to the fans.*

3

You must also observe the Caution and Warnings below:



Caution Make sure the fans are held stationary. The fans can be severely damaged if they are allowed to spin with the force of the compressed air.

Warnings (1) Use *only* a low-pressure compressed air source (25 psi or lower).

(2) To avoid personal injury, do not expose your eyes or skin to the direct jet of compressed air, since it can constitute a serious health hazard. Use suitable protection for your eyes and exposed skin.

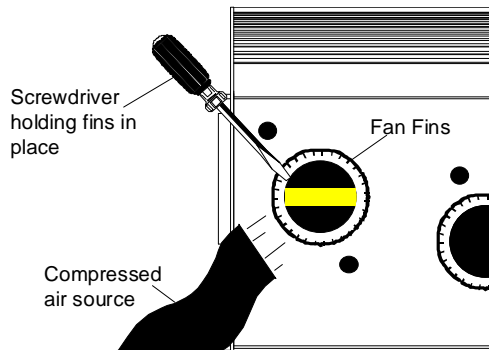

Figure 3-1. Holding the fan fins in place while you clean the fans using compressed air.

Cleaning the Internal Components

- You will need:**
- a soft, lint-free cotton cloth
 - mild glass cleaning solution
 - warm soapy water

Removing the Center Access Door

With the fixture bottom-side up, remove the center access door by sliding the two door thumb latches inward. Lift the door *straight up*, unhook the safety chain, and set it aside.

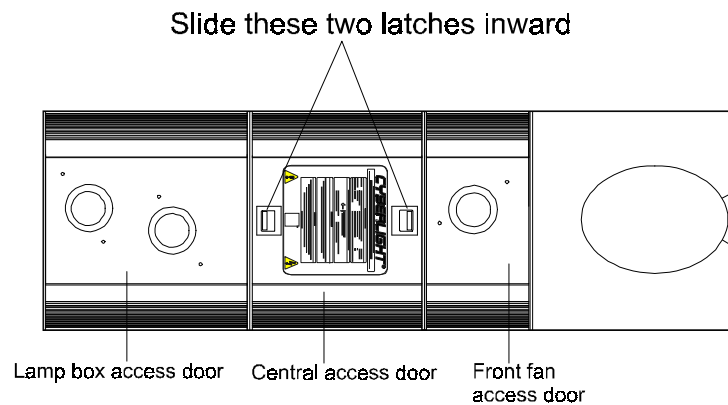

Figure 3-1. Bottom view of the Cyberlight fixture.

Cleaning the Mirror, Lenses, Motors and Iris

1. Using a soft, lint-free cotton cloth, remove dirt and dust from the motors, mirror, power lens, focus lens, and zoom lens. If necessary to remove built-up dirt and dust, clean the lenses with a mild glass cleaner and a soft lint-free cotton cloth.

Note The Cyberlight CX has no color mixing flags, motorized zoom lens, or frost flags. It does have a three-position mechanical zoom lens.

2. Clean the mirror with a cloth soaked in warm, soapy water (see Figure 3-2 for the location of the mirror).

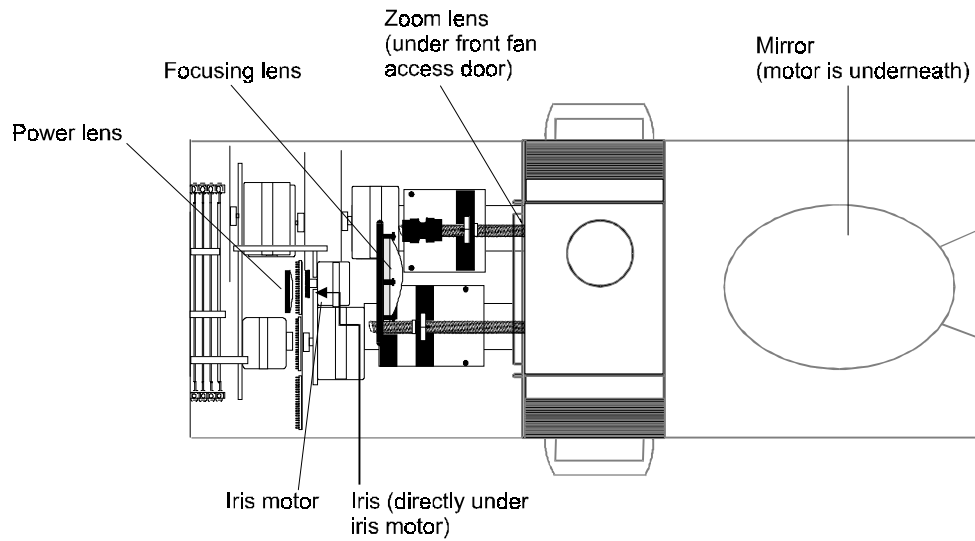

Figure 3-2. Locations of the iris, power lens, focusing lens, zoom lens and mirror.

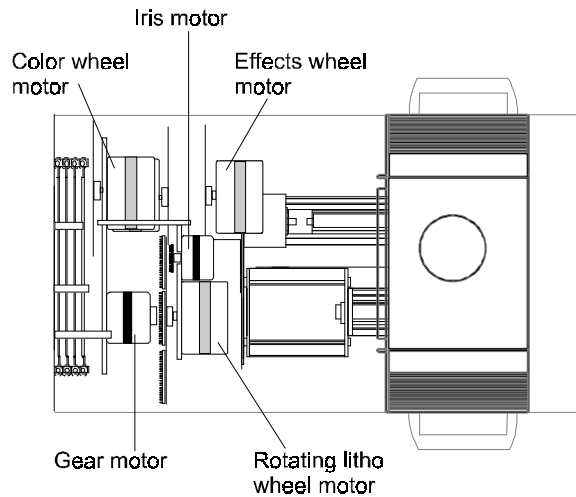

Figure 3-3. Locations of the motors.

3. Manually turn the rotating litho wheel until its open position is opposite the iris. (You will see the iris when looking toward the focusing lens through the open position on the rotating litho wheel.)

4. Manually close the iris by turning the large black-colored gear shown in Figure 3-4:

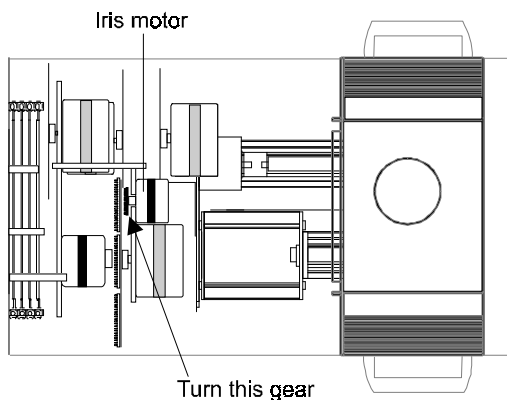

Figure 3-4. Close the iris by rotating the large black gear located on top of the iris motor.

5. Gently wipe away excess dust and dirt from the iris using a soft lint-free cloth. You can access one side of the iris through the open position on the rotating litho wheel; you can access the other side through the open position on the effects wheel.



Caution Be careful when cleaning the iris. It is made of a very thin, delicate metal that can be easily damaged.

6. Clean both sides of the anti-reflective glass (shown in Figure 3-5) with a soft, lint-free cotton cloth and mild glass cleaning solution.

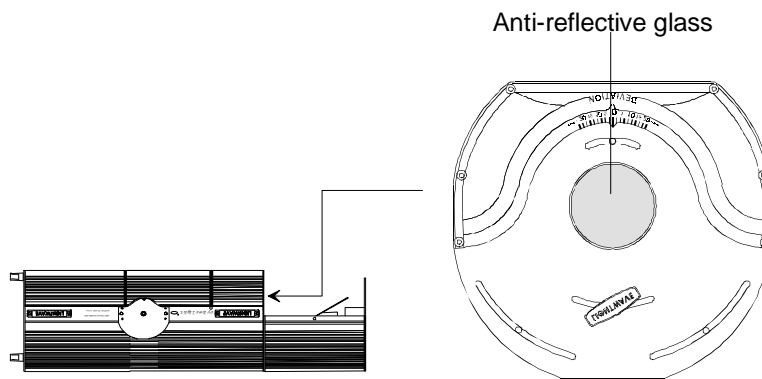

Figure 3-5. Cleaning the anti-reflective glass.

Cleaning the Color Wheel, Static Litho Wheel, Effects Wheel and Sensors

You will need:

- one 9/64 inch right angle allen wrench
- one 5/16 inch wrench

Use this procedure to remove and clean the color wheel, static litho wheel, and effects wheel; and to clean the sensors for the color wheel and the static litho wheel. High End Systems recommends removing the wheels for cleaning to prevent bending or deforming them.

The optical sensors, located below the color and litho wheels, electronically sense the homing slot on the edge of the wheel in order to keep track of the “home” positions of the respective wheels.

1. *This step applies to removing the static litho wheel only.* Manually rotate the color wheel until the open position is opposite the standoff you will remove next. The location of the standoff is shown in Figure 3-6.

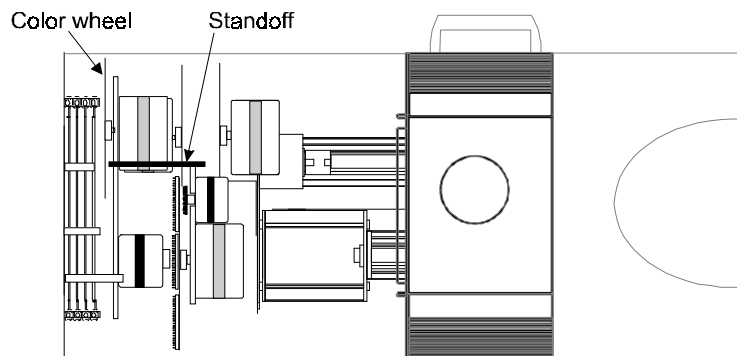

Figure 3-6. Removing the standoff between the iris motor and the color wheel.

2. *This step applies to removing the static litho wheel only.* Use a 9/64 inch right angle allen wrench to remove the two screws holding the standoff between the rotating litho assembly and the color wheel assembly. (You will need to insert the allen wrench through the open position on the color wheel in order to remove one of the screws.) Set the standoff aside.
3. Manually rotate the wheel until the large ends of the keyhole slots are facing down as shown in Figure 3-7.

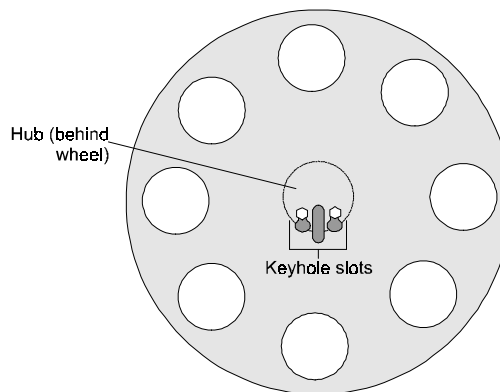

Figure 3-7. Make sure the wheel is positioned with the keyhole slots facing downward before removing it.

4. Holding the wheel in place with one hand, use a 5/16 inch wrench to loosen (do not remove) the two hex screws securing the wheel to its hub.
5. Pull up on the wheel to remove it from the hub. The large ends of the keyhole slots will slip over the two hex screws.
6. Clean the wheel with a mild glass cleaner and a soft cotton cloth. Make sure the homing slot (shown in Figure 3-8) is free of dust and dirt.

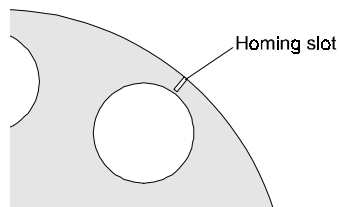

Figure 3-8. The homing slot is a small groove on the outside edge of the wheel. The static litho wheel and the color wheel's homing slots are in different locations. The effects wheel does not have a homing slot.

7. *This step applies to the color wheel and static litho wheel only.* Clean the groove in the wheel sensor. Figure 3-9 shows the location of the static litho wheel sensor. The color wheel has an identical sensor located underneath it.

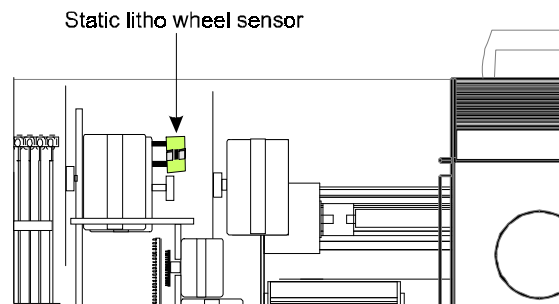

Figure 3-9. Clean the groove in the wheel sensor.

8. When you are finished cleaning the wheel and sensor, carefully slip the wheel back onto its hub. The large ends of the keyhole slots should be pointing down, which allows them to slip over the tops of the screws which secure the wheel to the hub. Make sure of the following:
 - *All but the effects wheel:* The wheel fits within the sensor slot, not outside of the slot.
 - *Static litho wheel:* Orient the coated/etched side of the litho *away from* the lamp; orient the glass side of the litho toward the lamp. Improper installation can damage the litho.

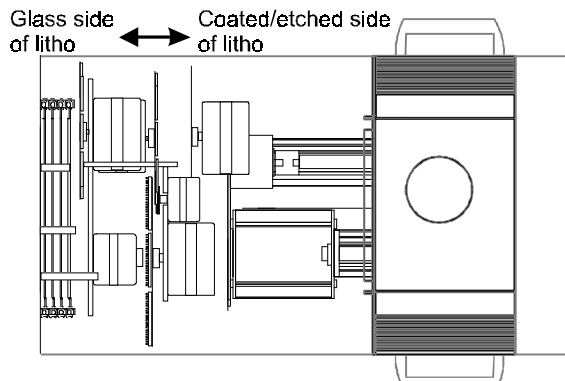

Figure 3-10. Static litho wheel lithos **must** be oriented with the coated/etched side facing away from the lamp.

- *Color wheel:* Orient the coated side of the color wheel dichroic filter toward the lamp; orient the glass side of the dichroic away from the lamp.

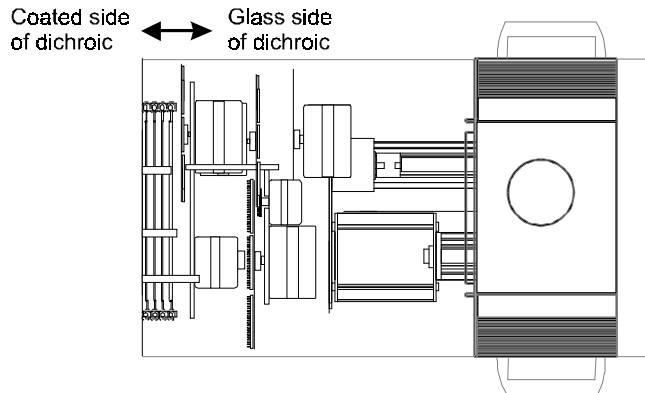

Figure 3-11. Color wheel dichroic filters should be oriented with the coated side of the dichroic facing toward the lamp and the glass side facing toward the static litho wheel.

Also make sure you do the following:

- Place the “slider” screw on the hub in the center of the middle keyhole slot, as shown in Figure 3-12 on page 3-10.
- Push the wheel until the two hex nuts are all the way onto the narrow ends of the keyhole slots before tightening the screws.
- Tighten the hex nuts until they are secure but do not overtighten. Doing so could damage the wheel.



Caution Be careful not to allow the lithos/dichroics to contact other objects when reinstalling the wheels. Doing so could scratch them.

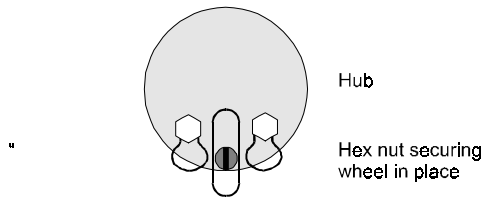

Figure 3-12. Position the keyhole slots so they fit over both hex screws as well as the “slider” screw inset in the hub.

9. Retighten the two screws that hold the wheel in place. Tighten the screws only until they are snug; do not overtighten.
10. Re-install the standoff you removed in Step 1 on page 3-7.

Cleaning the Infrared Filter, Reflector, Color Mixing Flags and Dim Flags

You will need: - one right angle 5/32 inch allen wrench

This section explains how to clean two components located inside the Cyberlight lamp box: the infrared filter and reflector. It also explains how to clean the color mixing flags and the dim flags, which are located on the other side of the lamp assembly.

- Cautions**
- (1) **Equipment surfaces may reach temperatures up to 62° C (144° F). Allow 10 minutes for cooling before handling.**
 - (2) **Change shields, lenses, or the infrared filter if they have become visibly damaged to such an extent that their effectiveness is impaired, for example by cracks or deep scratches.**

- Warnings**
- (1) **An unshielded MSR/MSD 1200 lamp emits ultraviolet and visible (UV-vis) radiation which could damage eyes and skin. Never look directly at the lamp while lamp is on.**

- (2) **Hot lamp may be an explosion hazard. Do not open for 5 minutes after switching off. Wear eye and hand protection when re-lamping.**

1. Allow the fixture to cool as described above then power it OFF and unplug it from the power source.

2. Fully back out the two lamp assembly screws shown in Figure 3-13. The screws have retaining springs that prevent them from being removed.

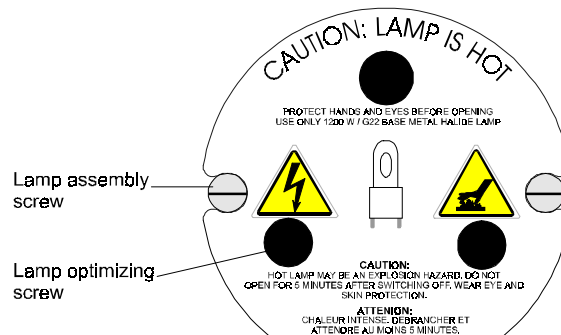

Figure 3-13. Location of lamp assembly and optimization screws.

3. Grip the three lamp optimizing screws and pull the lamp assembly straight out of the back of the fixture. The lamp's power cord is long enough to allow you to pull the lamp assembly entirely free of the Cyberlight.
4. Carefully set the lamp assembly aside. You can remove the lamp, if you wish, and place it where it will not get broken. Pull it straight out of the socket as shown in Figure 3-14.

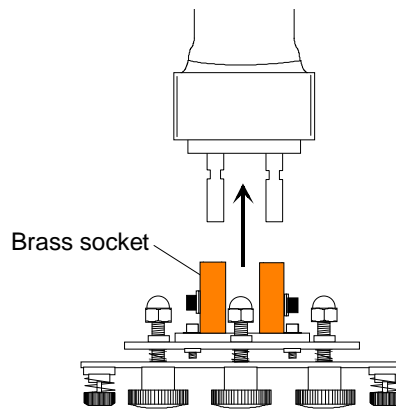

Figure 3-14. Removing the lamp from its brass socket.

5. Using the 5/32 inch right angle allen wrench, remove the four 5/32 inch allen screws shown in Figure 3-15.

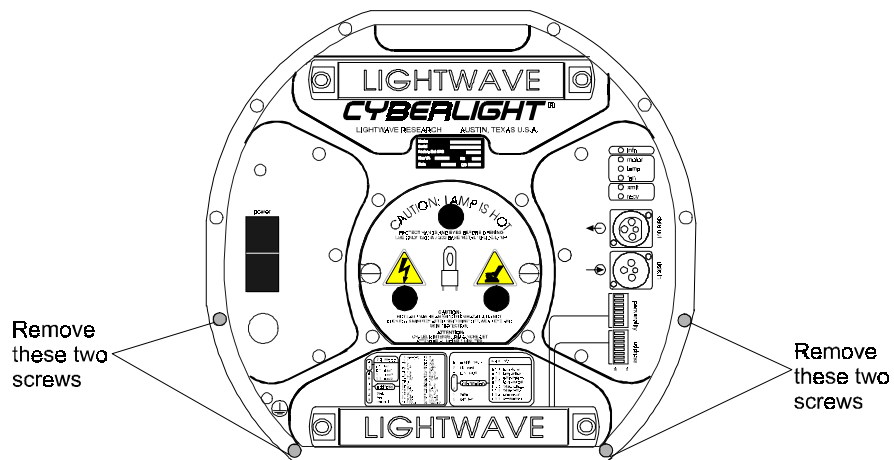

Figure 3-15. Location of the first four rear panel screws you need to remove in order to access the lamp assembly.

6. Remove the last two 5/32 inch allen head screws from the color mixing plate as shown in Figure 3-16. Carefully lift the lamp box access door from the fixture.

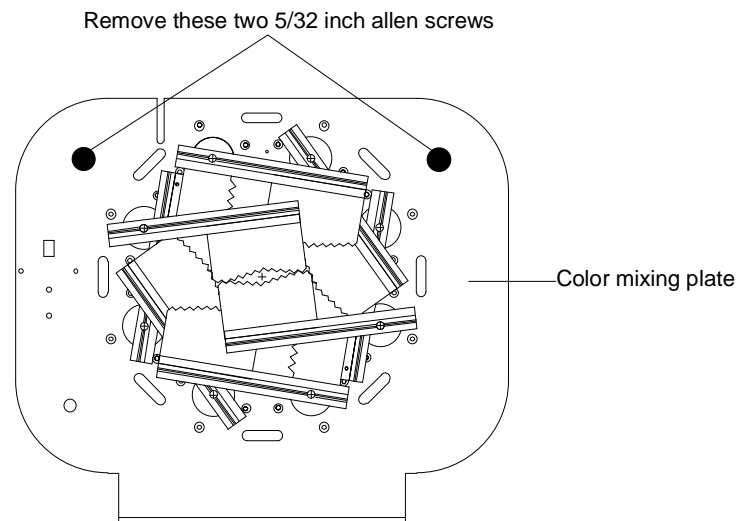

Figure 3-16. In order to remove the lamp box access door, you need to remove the last two 5/32 inch allen screws, which are located by the color mixing and dim flags.

7. *CL and CX models only:* As you lift the assembly, disconnect the two fan power connectors (black and red wires) from the power supply board as shown in Figure 3-17. Set the lamp box access door aside.

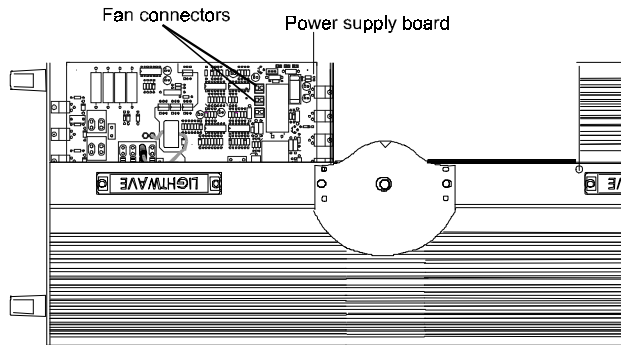

Figure 3-17. On CL and CX models, make sure you disconnect the fan power wires from the fan connectors before removing the lamp box access door.

8. Using a lint-free cotton cloth and mild glass cleaner, wipe dust and dirt from the reflector and infrared filter, which are shown in Figure 3-18. The infrared filter consists of two rose-colored glass hemispheres directly in front of the reflector.

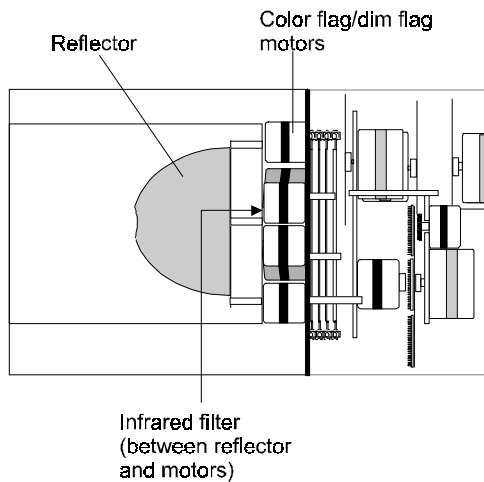

Figure 3-18. Locations of the reflector and infrared filter.

9. Using a soft, lint-free cotton cloth, wipe excess dirt and dust from the other side of the infrared filter and from the dim flags. There are two black, metallic dim flags on all Cyberlight models. Their locations are described below:
 - If you have the CL or SV, the two dim flags are among the color mixing flags, so you should clean all the flags at the same time. Manually “flip” each flag until it is in a position where you can access it, then wipe the flag with a lint-free cloth. Dampen the cloth with a mild glass cleaning solution if necessary to clean built-up dust and dirt. If a color mixing flag is damaged or broken, or if you need to remove it in order to clean it, contact Customer Service in one of the ways shown in the section titled “Getting Help” on page Intro-4.

- The CX has no color mixing flags. The two dim flags are located in the area shown in Figure 3-19.

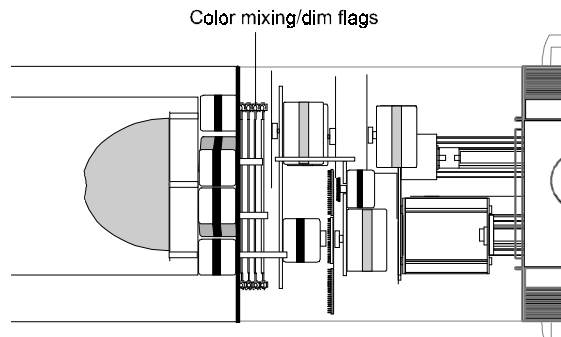

Figure 3-19. Location of the color mixing flags and dim flags.

10. Make sure the infrared filter, reflector, color mixing flags and dim flags are all clean.
11. Carefully guide the lamp assembly straight back into the fixture and make sure the lamp is inserted into the reflector. Be careful not to crimp the two lamp wires as you insert the lamp assembly. Firmly tighten the two lamp assembly screws (refer to Figure 3-13 on page 3-11) to secure the assembly to the fixture.
12. Reinstall the lamp assembly cover. Do the following:
 - *CL and CX only:* Reconnect the two fan wires to the Cyberlight power supply board. Refer back to Figure 3-17 on page 3-13.
 - Carefully replace the lamp box access door.
 - Reinstall the six 5/32 inch screws (refer to Figure 3-15 on page 3-12 and Figure 3-16 on page 3-12).

Removing and Cleaning the Rotating Lithos

You can clean the rotating lithos in or out of the rotating litho wheel using a mild glass cleaner and a soft cotton cloth. Turn the rotating wheel so that you have easy access to the litho then clean the lithos while they are still mounted in the wheel.

If you wish to remove the litho for cleaning follow the procedure in the section titled “Removing and Installing Rotating Lithos”. Then clean the litho with a mild glass cleaner and a soft lint free cloth.

Replacing Parts

This section explains how to remove and replace parts inside the fixture. Make note of the following caution and warnings:



Caution Equipment surfaces may reach temperatures up to 62° C (144° F). Allow 10 minutes for cooling before handling.

Warnings (1) An unshielded MSR/MSD 1200 lamp emits ultraviolet and visible (UV-vis) radiation which could damage eyes and skin. Never look directly at the lamp while lamp is on.



(2) Hot lamp may be an explosion hazard. Do not open for 5 minutes after switching off. Wear eye and hand protection when re-lamping.



(3) Replace fuses *only* with the specified type and rating.

(4) Disconnect power before re-lamping or servicing.

After allowing the fixture to cool as described above, turn it OFF and unplug it from its power source. Then see one of the following sections:

- “Replacing Power Supply Fuses” on page 3-15
- “Removing and Installing Rotating Lithos” on page 3-19
- “Replacing Dichroics/Lithos in the Color Wheel or the Static Litho Wheel” on page 3-22
- “Adjusting the Mechanical Zoom Lens (CX Only)” on page 3-23
- “Adjusting the Mirror Head Deviation” on page 3-24
- “Adjusting the Yoke Deviation” on page 3-26

Replacing Power Supply Fuses

This section explains how to replace the four fuses located on the Cyberlight power supply board.

You will need:

- 5/32 inch allen wrench
- Replacement fuses (5 mm by 20 mm only).

There are a total of four:

Amps	Volts	Fuse Type
2.5 A	250 V	Slow Blow Only
4 A	250 V	Fast Blow Only
0.5 A	250 V	Fast Blow Only
1.6 A	250 V	Fast Blow Only

1. After allowing the fixture to cool as described on the previous page, turn the power switch OFF and unplug the fixture.
2. With the fixture oriented bottom-side up, remove the center access door by sliding the two door latches inward. Lift the door *straight up*, unhook the safety chain, and set the door aside. See Figure 3-20.

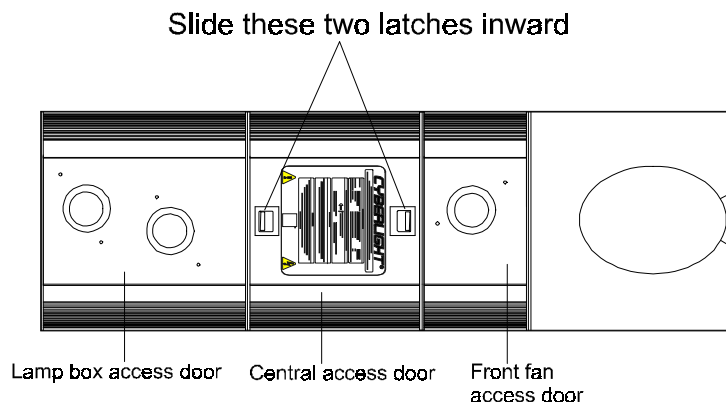

Figure 3-20. View of the bottom of the Cyberlight fixture, where the access door latches are located.

3. Remove the fixture's lamp box access door by removing the six 5/32 inch allen head screws securing it to the fixture as follows:
 - Remove the four 5/32 inch allen head screws from the bottom of the rear panel as shown in Figure 3-21.

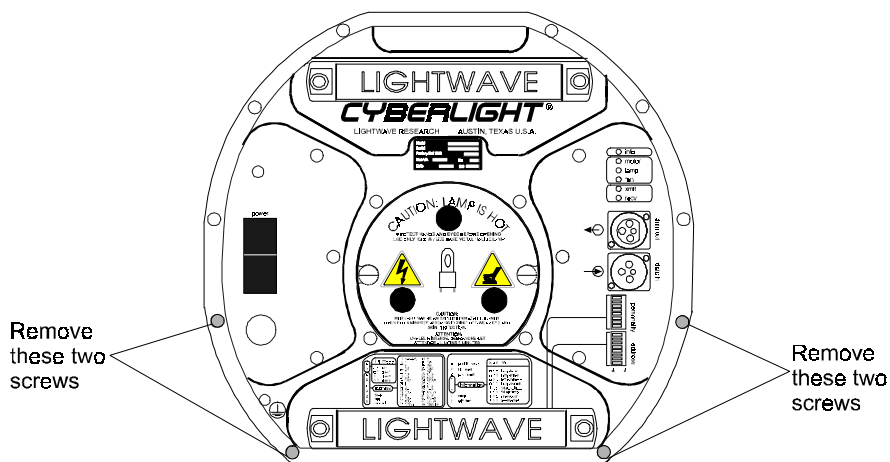

Figure 3-21. Removing the rear panel screws allows you to access the Cyberlight voltage selection jumpers.

- Remove the last two 5/32 inch allen head screws from the color mixing plate as shown in Figure 3-22. Carefully lift the lamp box access door from the fixture.

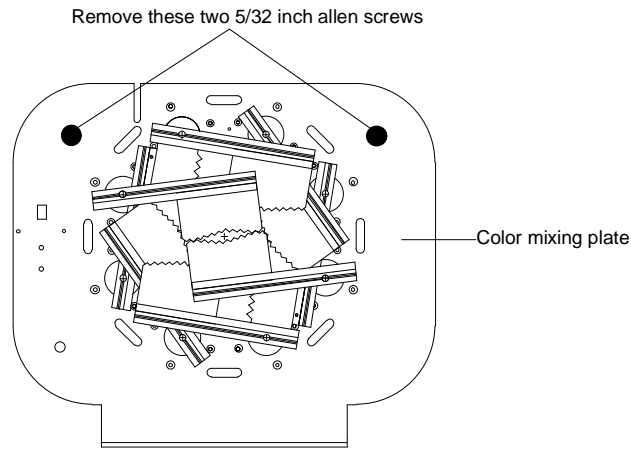

Figure 3-22. In order to remove the lamp box access door, you need to remove the last two 5/32 inch allen screws, which are located by the color mixing and dim flags.

- CL and CX models only: As you lift the assembly, disconnect the two fan wiring harness connectors (black and red wires) from the power supply board as shown in Figure 3-23. Set the lamp box access door aside. You now have access to the power supply board.

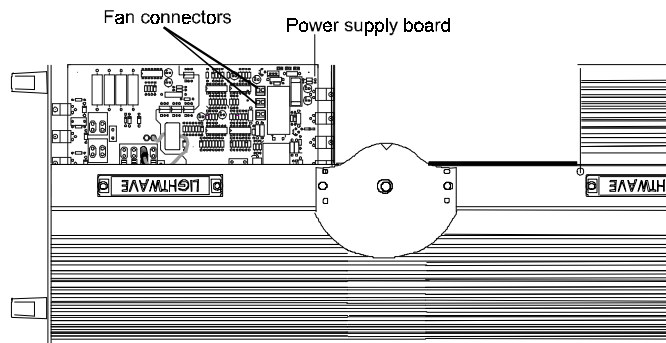

Figure 3-23. On CL and CX models, make sure you disconnect the fan power wires from the fan connectors before removing the lamp box access door.

- Note which fuse(s) needs to be replaced and make sure you replace it with a fuse of the same type and rating, as shown in the list below:

F1 = 2.5 A, 250 V, Slow Blow Only

F2 = 4 A, 250 V, Fast Blow Only

F3 = 0.5 A, 250 V, Fast Blow Only

F4 = 1.6 A, 250 V, Fast Blow Only

} 5 mm x 20 mm only

Table 3-1 below describes the function of each of the four power supply board fuses.

Table 3-1: Description and Function of Power Supply Board Fuses

Fuse	Type and Rating	Protects	Symptom
F1	2.5 A, 250 V	Input transformer	Fixture stops working; no functionality.
F2	4 A, 250 V	All 5 V power supplies	Fans won't work, control commands fail, lamp won't strike.
F3	0.5 A, 250 V	Data link power supply	Control commands pass-through only, lamp and fans work only in self-test.
F4	1.6 A, 250 V	Fans	Fans won't work, forcing fixture into thermal shutdown.

Fuses F1, F2 and F3 are located on either side of the large green-colored earth wire. Figure 3-24 shows the location of each fuse.

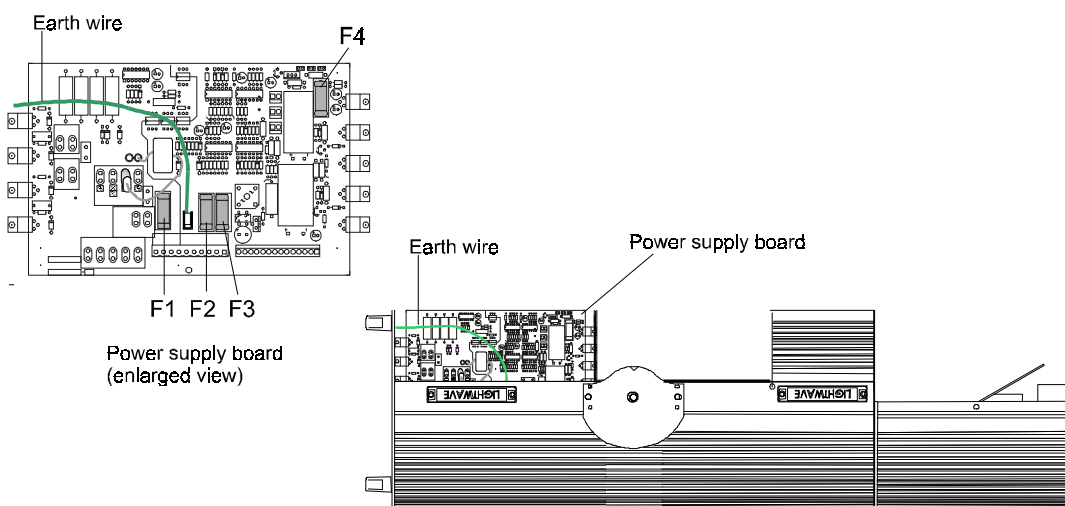

Figure 3-24. Location of power supply board fuses.

- Replace the lamp box access door by reversing this procedure and power the fixture ON.

Removing and Installing Rotating Lithos



This section explains how to remove and replace LithoPatterns lithos.

Please heed the following precautions when handling and using lithos:

- **Avoid touching the coated side of the glass. Handle the edge or uncoated side of the glass when removing or installing lithos. If possible, wear cloth gloves when inserting and removing lithos from the litho wheel housing.**
- **If necessary, clean the lithos with a mild glass cleaner and a soft cloth.**

3

Removing a Litho from the Rotating Litho Wheel

1. Remove the fixture's center access door as shown in Figure 3-25.

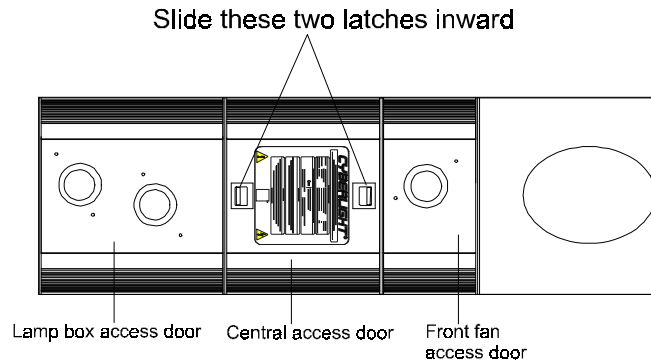

Figure 3-25. Removing the center access door.

2. Rotate the wheel until the desired litho is in a position for easy access.
3. Keep the rotating litho holder in place with one hand and grasp the spring tab with the other hand. Turn the spring; as you do so pull it away from each retainer washer. Continue pulling and turning the spring until it is loose enough to lift out of the housing.
4. Carefully remove the litho from the housing.

5. Insert the new or cleaned litho into the litho housing as shown in Figure 3-26. Make sure you orient the litho as explained below:
 - **Any LithoPatterns or any Psy-Dye lithos, including Psy-Dye Special Effects:** the coated side of the litho must face *away from* the lamp; uncoated (glass) side faces toward the lamp.
 - **Flat unglazed Art Glass or Special Effects *other than* Psy-Dye:** the non-textured side must face *away from* the lamp; textured side faces toward the lamp.
 - **Multi-Color lithos with stainless steel holder:** the solid flat side of the stainless steel litho holder must face *away from* the lamp (i.e., the flat side of the holder must be against the wheel hub).



Caution **Improper installation can result in heat damage to the litho. Use care when installing the litho; make sure you handle it by the edge only and do not allow it to contact any other object in the fixture while you are inserting it.**

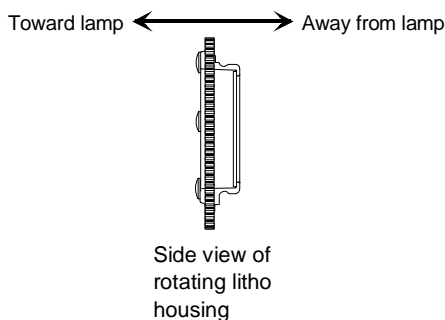

Figure 3-26. Insert the new or cleaned litho into the rotating litho housing as described above; improper installation can cause heat damage to the litho.

6. Insert the spring into the housing as shown in Figure 3-27.

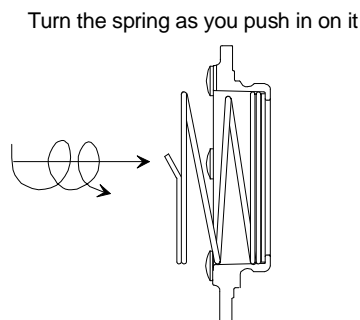

Figure 3-27. Turn on the spring as you push it into the rotating litho housing.

7. To lock the litho in place, begin working the spring under any one of the three retainer washers until the spring is fully compressed as shown in Figure 3-28. (The retaining washers are

shaded in the figure.)

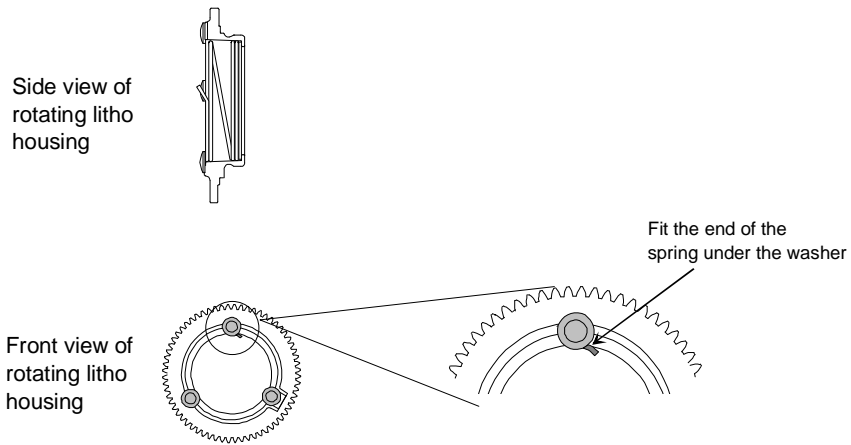

Figure 3-28. Make sure the end of the spring fits under any one of the three retaining washers, as shown above.



Caution Do not place the end of the spring anywhere else in the rotating litho wheel housing, as shown in Figure 3-29. Doing so could cause the spring to unwind and/or cause it to come into contact with other objects inside the fixture, possibly resulting in damage to the fixture.

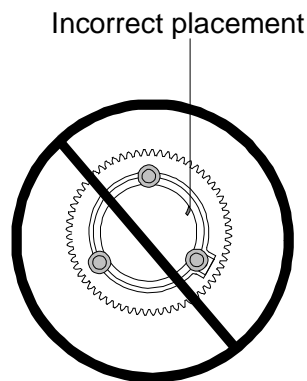

Figure 3-29. Do not place the end of the spring between the three retaining washers.

Replacing Dichroics/Lithos in the Color Wheel or the Static Litho Wheel

This section explains how to replace dichroic filters in the color wheel and how to replace lithos in the static litho wheel. (A *dichroic* is solid-colored with no etched pattern, while a *litho* has an etched pattern.)

Although the lithos and dichroics look different from each other, they are the same size and the wheels are the same size, so the procedure for replacing them is exactly the same.

You can replace dichroics/lithos if they are damaged or broken, to change the order in their respective wheels, or to add new ones. (See the section titled “Optional Accessories” on page 1-7 for ordering information.) Dichroics and lithos are also completely interchangeable between Cyberlight CLs, CXs and SVs.

1. Position the wheel so the dichroic/litho you wish to replace is easy to access.
2. *This step applies to replacing a litho only.* Position the effects wheel so the open position in the wheel aligns with the litho you wish to replace.
3. Push the dichroic/litho you wish to replace toward the center of the wheel to free it from the two wheel tabs as shown in Figure 3-30.

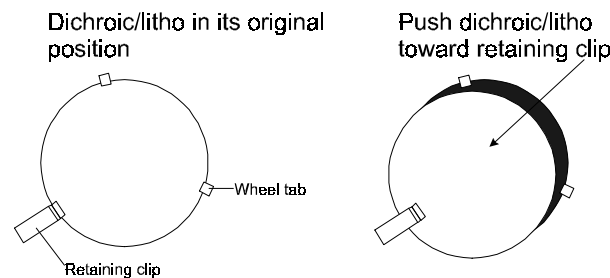

Figure 3-30. Push the dichroic/litho toward the large retaining tab to free it from the wheel tabs.

4. Once the dichroic/litho is free of the two wheel tabs, pull it out of the wheel. If you intend to reuse this dichroic/litho, put it in a safe place where it will not get scratched.
5. *Color wheel only:* Orient the dichroic filter so the coated side is facing toward the lamp and the uncoated, glass side is facing toward the static litho wheel.
6. *Static litho wheel only:* Orient the new litho so the etched side is facing away from the lamp (toward the effects wheel). The glass side must be facing the lamp. *Improper installation can damage the litho.*
7. Install the new dichroic/litho into its wheel by pushing it under the large retaining clip, then pull it up so it fits under the wheel tabs.

Adjustments

This section explains the Cyberlight CL, SV and CX fixture adjustments.

You will need: - #2 Phillips screwdriver
 - 9/64 inch allen wrench

Adjusting the Mechanical Zoom Lens (CX Only)

You can easily position the mechanical zoom lens to any of three zoom values:

Forward (position 1) is: ~ 12° Middle (position 2) is: ~ 14° Rear (position 3) is: ~ 18°

1. *Optional:* Remove the front fan access door for easier access to the lens assembly. Remove the four screws that fasten the fan assembly to the front plate with a #2 Phillips screwdriver. Also remove the 9/64 inch allen head screw from each side of the fan assembly. Lift the fan assembly out far enough to access the fan wires connector. Separate the connector and set the fan assembly aside.
2. The zoom lens assembly is fastened to the slide by two Phillips head screws. Remove the two screws, move the lens to desired position (1, 2, or 3), then, re-insert and tighten the two screws.

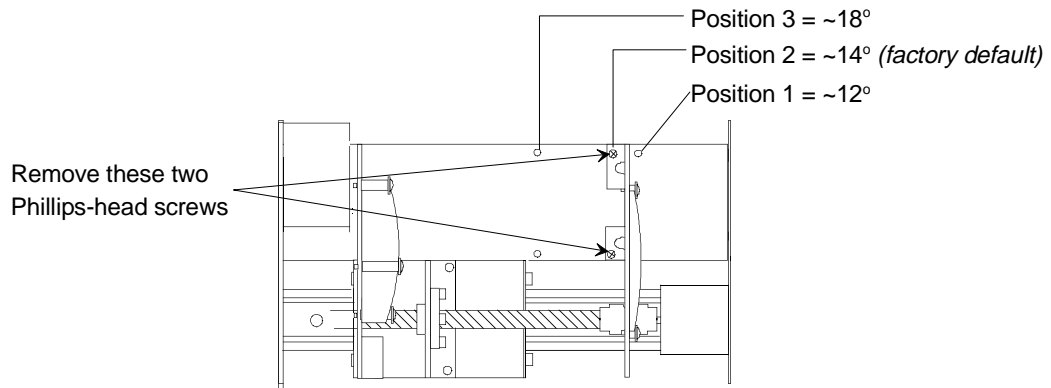

Figure 3-31. Adjusting the Cyberlight CX mechanical zoom lens.

Adjusting the Mirror Head Deviation

You will need: - 5/32 inch right angle allen wrench

You can easily pivot or offset the mirror head deviation up to 20 degrees left or right of center for a total range of 40 degrees.

1. Using an allen wrench, loosen the three 5/32 inch allen screws shown in Figure 3-32. Using your hand, loosen T-handle that locks the mirror head in position.

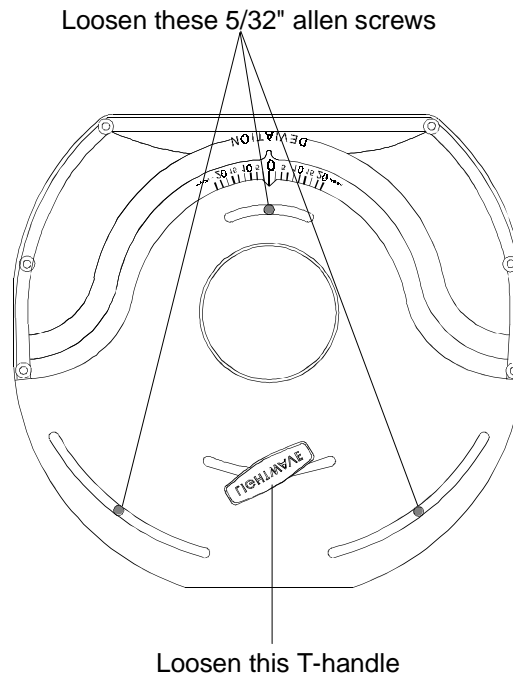

Figure 3-32. Loosen the three 5/32 inch allen screws and the T-handle to adjust the mirror head deviation.

Note The mirror head deviation adjustment can be performed with the Cyberlight positioned either on its back (as is shown in Figure 3-32) or on its front.

2. Grasp both sides of the mirror head and rotate it until it is positioned according to your needs. See Figure 3-33.

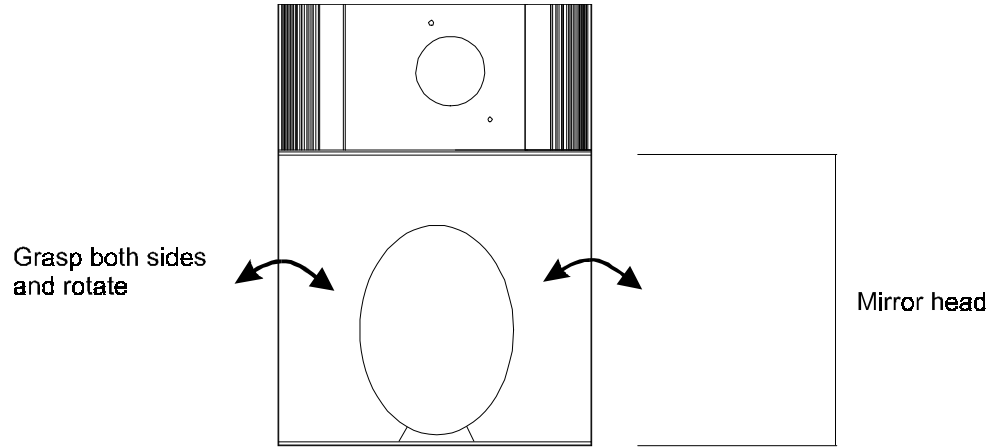

Figure 3-33. Grasp both sides of the mirror head and rotate it to the desired position.

3. Note the “Deviation” angle (see Figure 3-34) you are using, in case you wish to use the same deviation in other venues.

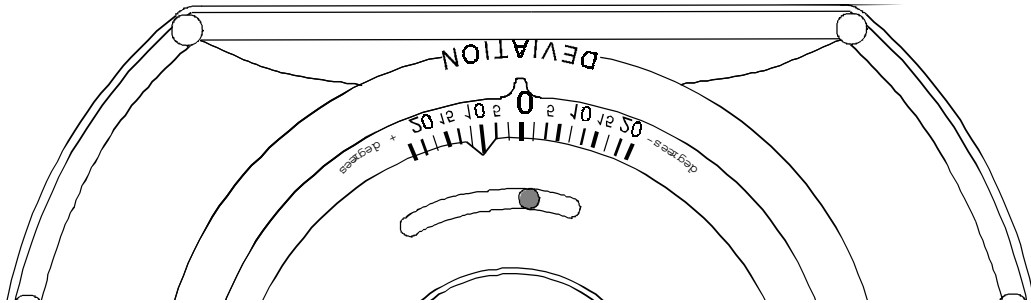

Figure 3-34. Be sure to note the deviation angle in case you need to set other fixtures for the same deviation, or if you want to use this exact deviation again. For example, the figure above has about a 10° + (plus) deviation.

4. When you are finished, retighten the three 5/32 inch allen screws and the T-handle so the mirror head is securely in position.

Adjusting the Yoke Deviation

You can adjust the yoke deviation to orient the Cyberlight in different positions. If you make note of the deviation angle, you can orient a group of Cyberlight fixtures in precisely the same direction. Figure 3-35 below shows how to adjust the yoke deviation.

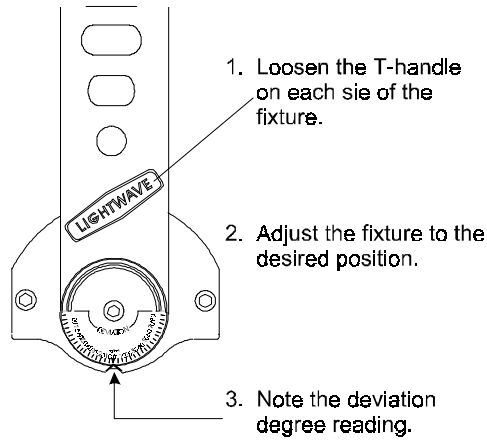

Figure 3-35. Adjust the yoke handles on both sides of the Cyberlight to tilt the fixture in a specific way.

Appendix A

DMX Control of Cyberlight®

Use this appendix to control your Cyberlight fixtures using DMX 512 modes 1, 2, and 3.

Overview

The Cyberlight is a block-addressed fixture; that is, you do not address it at an arbitrary DMX start channel, but rather at a *channel boundary*. There are two channel boundaries you can select: 15-channel and 20-channel. If you choose to control your Cyberlight on a 20-channel boundary, for example, each fixture takes up a contiguous *block* of 20 DMX channels.

Selecting a DMX Mode

The three DMX modes available for your Cyberlight provide three different levels of control and flexibility, and can be used with CLs, SVs, and CXs as summarized below:

- **Mode 1:** standard 20-channel control.
- **Mode 2 (*recommended*):** enhanced 20-channel control. Mode 2 offers the same features as mode 1 but at greater resolution (for example, mode 2 supports frost strobing and 96 shutter strobe speeds while mode 1 does not support frost strobing and supports only eight shutter strobe speeds).
- **Mode 3:** minimal 15-channel minimal control. Mode 3 *does not* support color mixing or zoom. You can select mode 3 in two possible situations:
 - You are controlling only CXs on a link. Mode 3 utilizes all CX features but does not support color mixing or zoom, which are supported by CLs and SVs only.
 - You do not have enough available DMX channels on the link to allocate 20 channels per Cyberlight fixture. (Mode 3 also supports up to 34 fixtures per link, while modes 1 and 2 both support up to 25 fixtures per link.)

Note Modes 1, 2 and 3 are supported by all Cyberlight models. If you have any Cyberlight CXs on the link, they will not respond to color mixing or zoom commands, but will otherwise respond to commands identically to CLs and SVs.

Performing Software Uploads Over a Link

Software uploads can be performed over a link using either a Link Card or the Cyberlight Upload Module. Fixtures automatically switch to LWR protocol for the upload, then switch back to DMX control after the upload has been successfully completed. Consult the Status Cue software documentation or the Upload Module for the procedure.

Note There are two things that can stop software uploads to a Cyberlight: a data distributor and certain High End Systems equipment on the same link. You must bypass any data distributors when performing a software upload on a link. Also review the section titled “Controlling Multiple High End Systems Fixtures on the Same Link” on page 2-3.

A

Address DIP Switches

Figure A-1 below shows a functional breakdown of the eight DMX address DIP switches, located on the Cyberlight fixture's rear panel. (Review "Identifying Rear Panel Components" on page 1-8 for the location of the switches).

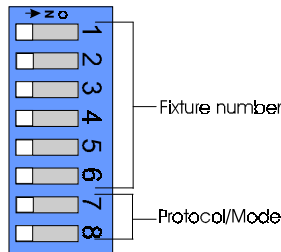

Figure A-1. The DMX address switch block allows you to select the control protocol (DMX 1, DMX 2, DMX 3, or LWR) and the fixture number.

Related Topics

Other information you might need to reference when assigning DMX channel numbers is summarized below:

- The section titled "Channel Boundaries" on page A-18 explains the relationship between fixture number (which you set with the address DIP switches) and actual DMX address ranges.
- The section titled "Choosing DMX 512 or LWR Protocol" on page 2-2 explains what to consider before selecting either DMX 512 or Lightwave Research (LWR) control protocol.
- The section titled "Controlling Multiple High End Systems Fixtures on the Same Link" on page 2-3 explains important considerations when mixing Cyberlight fixtures, Intellabeam fixtures, Emulator fixtures, and AF1000 fixtures on the same link.

Accessing Control Information

In order to access the control channel (channel 20 in 20-channel DMX modes 1 and 2 and channel 15 in 15-channel DMX mode 3), you must follow the procedure below:

1. Put the dim channel and the control channel at full.
2. Put the dim channel at zero and the control channel at full.
3. (*Must occur within 3 seconds*): Put the dim channel at zero. Put the control channel at: 25% for home or 50% for shutdown.
4. Hold for an additional 3 seconds.

Rounding Conventions

The values displayed in the "Range" and "Channel Value" columns in the following tables may vary slightly depending on your controller's rounding convention.

DMX 512 Mode 1 – Standard Cyberlight[®] DMX Control

Each Cyberlight fixture in DMX mode 1 uses 20 channels of the DMX 512 protocol thus providing control for up to 25 fixtures ($512 / 20 = 25.6$ fixtures). Use the procedure below to control your Cyberlight with DMX mode 1:

1. Set the fixture to DMX mode 1 by setting address switch 7 to OFF and address switch 8 to ON.
2. Set address switches 1 through 5 to correspond to the desired fixture number, as shown in Table A-1. Note that Cyberlight CX fixtures configured for 20-channel mode work properly and can be mixed with Cyberlight fixtures; they do not respond to the color mixing, zoom, or variable frost constructs.
3. Refer to Table A-2 for the Cyberlight DMX 20-channel assignments.

Table A-1: Addressing Fixtures in 20-Channel DMX 512 Mode 1

Cyberlight Fixture	Fixture Address Switches ON	DMX Channel Number	Cyberlight Fixture	Fixture Address Switches ON	DMX Channel Number
Fixture 1	none	001	Fixture 14	1, 3, and 4	261
Fixture 2	1	021	Fixture 15	2, 3, and 4	281
Fixture 3	2	041	Fixture 16	1, 2, 3, and 4	301
Fixture 4	1 and 2	061	Fixture 17	5	321
Fixture 5	3	081	Fixture 18	1 and 5	341
Fixture 6	1 and 3	101	Fixture 19	2 and 5	361
Fixture 7	2 and 3	121	Fixture 20	1, 2, and 5	381
Fixture 8	1, 2, and 3	141	Fixture 21	3 and 5	401
Fixture 9	4	161	Fixture 22	1, 3, and 5	421
Fixture 10	1 and 4	181	Fixture 23	2, 3, and 5	441
Fixture 11	2 and 4	201	Fixture 24	1, 2, 3, and 5	461
Fixture 12	1, 2, and 4	221	Fixture 25	4 and 5	481
Fixture 13	3 and 4	241			



Table A-2: Cyberlight DMX Assignments Mode 1

Channel	Assignment	Range	Construct Parameter
Channel 1	Pan coarse adjustment		Position
Channel 2	Pan fine adjustment		Position
Channel 3	Tilt coarse adjustment		Position
Channel 4	Tilt fine adjustment		Position

Table A-2: Cyberlight DMX Assignments Mode 1

Channel	Assignment	Range	Construct Parameter
Channel 5	Color Wheel	<p style="text-align: center;">Full</p>  <p style="text-align: center;">0</p>	Color 1 (open) Half color 1 and 2 Color 2 Half color 2 and 3 Color 3 Half color 3 and 4 Color 4 Half color 4 and 5 Color 5 Half color 5 and 6 Color 6 Half color 6 and 7 Color 7 Half color 7 and 8 Color 8 Half color 8 and 1 Forward spin speed 8 Forward spin speed 7 Forward spin speed 6 Forward spin speed 5 Forward spin speed 4 Forward spin speed 3 Forward spin speed 2 Forward spin speed 1 Reverse spin speed 1 Reverse spin speed 2 Reverse spin speed 3 Reverse spin speed 4 Reverse spin speed 5 Reverse spin speed 6 Reverse spin speed 7 Reverse spin speed 8 Color 1 (open)
Channel 6	Cyan (Red)		Color Mix
Channel 7	Magenta (Green)		Color Mix
Channel 8	Yellow (Blue)		Color Mix

Table A-2: Cyberlight DMX Assignments Mode 1



Channel	Assignment	Range	Construct Parameter
Channel 9	Static litho	<p>Full</p>  <p>0</p>	Litho 1 (open) Litho 2 Litho 3 Litho 4 Litho 5 Litho 6 Litho 7 Litho 8 Forward spin speed 8 Forward spin speed 7 Forward spin speed 6 Forward spin speed 5 Forward spin speed 4 Forward spin speed 3 Forward spin speed 2 Forward spin speed 1 Reverse spin speed 1 Reverse spin speed 2 Reverse spin speed 3 Reverse spin speed 4 Reverse spin speed 5 Reverse spin speed 6 Reverse spin speed 7 Reverse spin speed 8 Litho 1 (open)
Channel 10	Rotating Litho Select the litho to rotate forward/reverse with this channel. Then use Channel 11 to set the rotation speed. For rotating litho position parameters select the litho position to index with this channel. Then use Channel 11 to set the rotational position (index value) from 0 to 360 degrees.	<p>Full</p>  <p>0</p>	Position 3 (open) Reverse rotate 5 Reverse rotate 4 Reverse rotate 2 Reverse rotate 1 Forward rotate 5 Forward rotate 4 Forward rotate 2 Forward rotate 1 Position 5 Position 4 Position 3 (open) Position 2 Position 1 Position 3 (open)
Channel 11	Rotate (use with Channel 10)		For Rotating Litho rotate mode use Ch 11 to set rotate speed For Rotating Litho position mode use Ch 11 to set the index from 0 to 360 degrees
Channel 12	Zoom		Zoom in/out
Channel 13	Focus		Focus in/out
Channel 14	Iris		Iris open/close

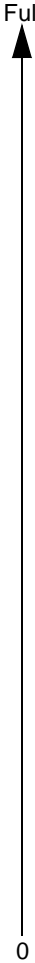

Table A-2: Cyberlight DMX Assignments Mode 1

Channel	Assignment	Range	Construct Parameter
Channel 15	Effects Wheel	Full ↑ 0	Effect 4 (open) Effect 8 Effect 7 Effect 6 Effect 5 Effect 4 Effect 3 Effect 2 Effect 1 Effect 4 (open)
Channel 16	Frost		Frost in/out
Channel 17	Shutter	Full ↑ 0	Open Closed Strobe speed 8 Strobe speed 7 Strobe speed 6 Strobe speed 5 Strobe speed 4 Strobe speed 3 Strobe speed 2 Strobe speed 1 Open Closed
Channel 18	Dim		Dim open/close
Channel 19	Motor Speed	Full ↑ 0	Speed 99 Speed 1 Speed 94
Channel 20*	Control		50% fader – shutdown 25% fader – home

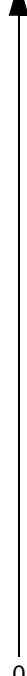
* - Make sure you first follow the instructions in the section titled “Accessing Control Information” on page A-2.

DMX 512 Mode 2 – Enhanced Cyberlight® DMX Control

Each Cyberlight fixture in DMX mode 2 uses 20 channels of the DMX 512 protocol thus providing control for up to 25 fixtures (512 / 20 = 25.6 fixtures). Use the procedure below to control your Cyberlight with DMX mode 2:

1. Set the Cyberlight fixture to DMX mode 2 by setting address switch 7 to ON and address switch 8 to OFF.
2. Set address switches 1 through 5 to correspond to the desired fixture number, as shown in Table A-3. Note that Cyberlight CX fixtures configured for 20-channel mode work properly and can be mixed with Cyberlight fixtures; they do not respond to the color mixing, zoom, and frost constructs.
3. Refer to Table A-4 for the Cyberlight DMX mode 2 channel assignments.

Table A-3: Addressing Fixtures in 20 Channel DMX 512 Mode 2

Cyberlight Fixture	Fixture Address Switches ON	DMX Channel Number	Cyberlight Fixture	Fixture Address Switches ON	DMX Channel Number
Fixture 1	none	001	Fixture 14	1, 3, and 4	261
Fixture 2	1	021	Fixture 15	2, 3, and 4	281
Fixture 3	2	041	Fixture 16	1, 2, 3, and 4	301
Fixture 4	1 and 2	061	Fixture 17	5	321
Fixture 5	3	081	Fixture 18	1 and 5	341
Fixture 6	1 and 3	101	Fixture 19	2 and 5	361
Fixture 7	2 and 3	121	Fixture 20	1, 2, and 5	381
Fixture 8	1, 2, and 3	141	Fixture 21	3 and 5	401
Fixture 9	4	161	Fixture 22	1, 3, and 5	421
Fixture 10	1 and 4	181	Fixture 23	2, 3, and 5	441
Fixture 11	2 and 4	201	Fixture 24	1, 2, 3, and 5	461
Fixture 12	1, 2, and 4	221	Fixture 25	4 and 5	481
Fixture 13	3 and 4	241			

A

The “Channel Value (%)” column in Table A-4 below has values you should use if your controller has dimmer-type controls. The “Channel Value (numerical)” column has values you should use if you are using the Status Cue system or another controller that uses digital or numerical controls.

Table A-4: Cyberlight DMX Assignments Mode 2

Channel	Assignment	Channel Value (%)	Channel Value (numerical)	Construct Parameter
Channel 1	Pan coarse adjustment	0-100%	0-255	Position
Channel 2	Pan fine adjustment	0-100%	0-255	Position
Channel 3	Tilt coarse adjustment	0-100%	0-255	Position
Channel 4	Tilt fine adjustment	0-100%	0-255	Position
Channel 5	Color Wheel	Full	255	Color 1 (open)
	<i>Full Speed</i>	98	250	Half color 1 and 2
		96	245	Color 2
		94	240	Half color 2 and 3
		93	237	Color 3
		91	232	Half color 3 and 4
		90	230	Color 4
		88	224	Half color 4 and 5
		87	222	Color 5
		85	217	Half color 5 and 6
		83	211	Color 6
		82	209	Half color 6 and 7
		80	204	Color 7
		79	201	Half color 7 and 8
		77	196	Color 8
		76	194	Half color 8 and 1
Channel 5	Color Wheel	74	189	Color 1 (open)
	<i>Mspeed</i>	73	186	Half color 1 and 2
		71	181	Color 2
		70	179	Half color 2 and 3
		68	173	Color 3
		66	168	Half color 3 and 4
		65	166	Color 4
		63	161	Half color 4 and 5
		62	158	Color 5
		61	156	Half color 5 and 6
		59	150	Color 6
		57	145	Half color 6 and 7
		56	143	Color 7
		54	138	Half color 7 and 8
		52	133	Color 8
		51	130	Half color 8 and 1

Table A-4: Cyberlight DMX Assignments Mode 2

Channel	Assignment	Channel Value (%)	Channel Value (numerical)	Construct Parameter
	Color Wheel <i>Spin Speed</i>	50 ↑ 26 25 ↑ 0 0	127 ↑ 66 64 ↑ 2 0	Forward spin speed – fastest • • • Forward spin speed – slowest Reverse spin speed – slowest • • • Reverse spin speed – fastest Color 1 (open)
Channel 6	Cyan (Red)	0-100%	0-255	Color Mix
Channel 7	Magenta (Green)	0-100%	0-255	Color Mix
Channel 8	Yellow (Blue)	0-100%	0-255	Color Mix
Channel 9	Static litho <i>Full Speed</i>	Full 98 96 94 93 91 90 88 87 85 83 82 80 79 77 76	255 250 245 240 237 232 230 224 222 217 211 209 204 201 196 194	Litho 1 (open) Litho 1 shake wide Litho 2 Litho 2 shake wide Litho 3 Litho 3 shake wide Litho 4 Litho 4 shake wide Litho 5 Litho 5 shake wide Litho 6 Litho 6 shake wide Litho 7 Litho 7 shake wide Litho 8 Litho 8 shake wide
	Static litho <i>Mspeed</i>	74 73 71 70 68 66 65 63 62 61 59 57 56 54 52 51	189 186 181 179 173 168 166 161 158 156 150 145 143 138 133 130	Litho 1 (open) Litho 1 shake narrow Litho 2 Litho 2 shake narrow Litho 3 Litho 3 shake narrow Litho 4 Litho 4 shake narrow Litho 5 Litho 5 shake narrow Litho 6 Litho 6 shake narrow Litho 7 Litho 7 shake narrow Litho 8 Litho 8 shake narrow



Table A-4: Cyberlight DMX Assignments Mode 2

Channel	Assignment	Channel Value (%)	Channel Value (numerical)	Construct Parameter
	Static litho <i>Spin Speed</i>	50 ↑ 26 25 ↑ 0 0	127 ↑ 66 64 ↑ 2 0	Forward spin speed – fastest • • • Forward spin speed – slowest Reverse spin speed – slowest • • • Reverse spin speed – fastest Litho 1 (open)
Channel 10	Rotating Litho <i>Full Speed</i> Select the litho to rotate (forward/reverse) with this channel. Then use Channel 11 to set the rotation speed. For rotating litho position parameters select the litho position to index with this channel. Then use Channel 11 to set the rotational position (index value) from 0 to 360 degrees.	Full 98 95 91 87 83 80 76 72 68 64 61 58 54	255 250 242 232 222 212 204 194 184 173 163 156 150 138	Position 3 (open) Reverse rotate 5 Reverse rotate 4 Reverse rotate 2 Reverse rotate 1 Forward rotate 5 Forward rotate 4 Forward rotate 2 Forward rotate 1 Position 5 Position 4 Position 3 (open) Position 2 Position 1
	<i>Mspeed</i>	50 46 42 39 36 32 28 24 20 17 13 10 5 0	127 117 107 99 92 82 71 61 51 43 33 26 13 0	Reverse rotate 5 Reverse rotate 4 Reverse rotate 2 Reverse rotate 1 Forward rotate 5 Forward rotate 4 Forward rotate 2 Forward rotate 1 Position 5 Position 4 Position 3 (open) Position 2 Position 1 Position 3 (open)
Channel 11	Rotate (use with Channel 10)	0-100%	0-255	For Rotating Litho rotate mode use Ch 11 to set rotate speed For Rotating Litho position mode use Ch 11 to set the index from 0 to 360 degrees
Channel 12	Zoom	0-100%	0-255	Zoom in/out
Channel 13	Focus	0-100%	0-255	Focus in/out
Channel 14	Iris	0-100%	0-255	Iris open/close

Table A-4: Cyberlight DMX Assignments Mode 2

Channel	Assignment	Channel Value (%)	Channel Value (numerical)	Construct Parameter
Channel 15	Effects Wheel Full Speed	Full 96 91 85 80 73 67 62 56	255 245 232 217 204 186 171 158 143	Effect 4 – (open) Effect 8 – cyan color corrector Effect 7 – diffusion Effect 6 – wide angle Effect 5 – magenta color corrector Effect 4 – (open) Effect 3 – yellow color corrector Effect 2 – CYM tri-color mosaic Effect 1 – prism
Channel 15	Effects Wheel <i>Mspeed</i>	50 44 37 33 27 21 14 8 0	127 112 94 84 69 54 36 20 0	Effect 8 – cyan color corrector Effect 7 – diffusion Effect 6 – wide angle Effect 5 – magenta color corrector Effect 4 – (open) Effect 3 – yellow color corrector Effect 2 – tri color mosaic (C-Y-M) Effect 1 – prism Effect 4 – (open)
Channel 16	Frost <i>Frost variable</i> None to full	Full ▲ 50	255 ▲ 129	Frost – frost free . . . Frost – frost full
	Frost <i>Full Frost Strob</i> (Frost in)	50 ▲ 0 0	126 ▲ 2 0	Frost strobing – fastest . . . Frost strobing – slowest Frost – frost free
Channel 17	Shutter <i>Strobe</i> 50 % duty cycle	Full 98 97 ▲ 1 1 0	255 250 247 ▲ 4 1 0	Open Closed Strobe speed – fastest . . . Strobe speed – slowest Open Closed
Channel 18	Dim	100 ▲ 0	255 ▲ 0	No dim Full dim (blackout)
Channel 19	Motor Speed	Full ▲ 0	255-200 ▲ 21 0	Speed 99 . . . Speed 1 Speed 95



Table A-4: Cyberlight DMX Assignments Mode 2

Channel	Assignment	Channel Value (%)	Channel Value (numerical)	Construct Parameter
Channel 20*	Control	50% 25%	128 64	shutdown home

* - Make sure you first follow the instructions in the section titled "Accessing Control Information" on page A-2.

DMX 512 Mode 3 – Cyberlight® 15-Channel DMX Control

Each Cyberlight fixture in DMX mode 3 uses 15 channels of the DMX 512 protocol thus providing control for up to 34 fixtures ($512 / 15 = 34.1$ fixtures). Use the procedure below to control your Cyberlight with DMX mode 3:

1. Set the Cyberlight fixture to DMX mode 3 by setting address switches 7 and 8 to ON.
2. Set address switches 1 through 6 as shown in Table A-5.
3. Refer to Table A-6 for the Cyberlight 15-channel assignments.

Table A-5: Addressing Fixtures in 15 Channel DMX 512 Mode 3

Cyberlight Fixture	Fixture Address Switches ON	DMX Channel Number	Cyberlight Fixture	Fixture Address Switches ON	DMX Channel Number
Fixture 1	none	001	Fixture 18	1 and 5	256
Fixture 2	1	016	Fixture 19	2 and 5	271
Fixture 3	2	031	Fixture 20	1,2, and 5	286
Fixture 4	1 and 2	046	Fixture 21	3 and 5	301
Fixture 5	3	61	Fixture 22	1, 3, and 5	316
Fixture 6	1 and 3	076	Fixture 23	2, 3, and 5	331
Fixture 7	2 and 3	091	Fixture 24	1, 2, 3, and 5	346
Fixture 8	1, 2, and 3	106	Fixture 25	4 and 5	361
Fixture 9	4	121	Fixture 26	1, 4, and 5	376
Fixture 10	1 and 4	136	Fixture 27	2, 4, and 5	391
Fixture 11	2 and 4	151	Fixture 28	1, 2, 4, and 5	406
Fixture 12	1, 2, and 4	166	Fixture 29	3, 4, and 5	421
Fixture 13	3 and 4	181	Fixture 30	1, 3, 4, and 5	436
Fixture 14	1, 3, and 4	196	Fixture 31	2, 3, 4, and 5	451
Fixture 15	2, 3, and 4	211	Fixture 32	1, 2, 3, 4, and 5	466
Fixture 16	1, 2, 3, and 4	226	Fixture 33	6	481
Fixture 17	5	241	Fixture 34	1 and 6	496



Table A-6: Cyberlight DMX Assignments Mode 3

Channel	Assignment	Range %	Construct Parameter
Channel 1	Pan coarse adjustment		Position
Channel 2	Pan fine adjustment		Position
Channel 3	Tilt coarse adjustment		Position
Channel 4	Tilt fine adjustment		Position
Channel 5	Color Wheel <i>Full Speed</i>	Full 98 96 94 93 91 90 88 87 85 83 82 80 79 77 76	Color 1 (open) Half color 1 and 2 Color 2 Half color 2 and 3 Color 3 Half color 3 and 4 Color 4 Half color 4 and 5 Color 5 Half color 5 and 6 Color 6 Half color 6 and 7 Color 7 Half color 7 and 8 Color 8 Half color 8 and 1
	Color Wheel <i>Mspeed</i>	74 73 71 70 68 66 65 63 62 61 59 57 56 54 52 51	Color 1 (open) Half color 1 and 2 Color 2 Half color 2 and 3 Color 3 Half color 3 and 4 Color 4 Half color 4 and 5 Color 5 Half color 5 and 6 Color 6 Half color 6 and 7 Color 7 Half color 7 and 8 Color 8 Half color 8 and 1
	Color Wheel <i>Spin Speed</i>	50 ↑ 26 25 ↑ 0 0	Forward spin speed – fastest • • • Forward spin speed – slowest Reverse spin speed – slowest • • • Reverse spin speed – fastest Color 1 (open)

Table A-6: Cyberlight DMX Assignments Mode 3

Channel	Assignment	Range %	Construct Parameter
Channel 6	Static litho <i>Full Speed</i>	Full 98 96 94 93 91 90 88 87 85 83 82 80 79 77 76	Litho 1 (open) Litho 1 shake wide Litho 2 Litho 2 shake wide Litho 3 Litho 3 shake wide Litho 4 Litho 4 shake wide Litho 5 Litho 5 shake wide Litho 6 Litho 6 shake wide Litho 7 Litho 7 shake wide Litho 8 Litho 8 shake wide
	Static litho <i>Mspeed</i>	74 73 71 70 68 66 65 63 62 61 59 57 56 54 52 51	Litho 1 (open) Litho 1 shake narrow Litho 2 Litho 2 shake narrow Litho 3 Litho 3 shake narrow Litho 4 Litho 4 shake narrow Litho 5 Litho 5 shake narrow Litho 6 Litho 6 shake narrow Litho 7 Litho 7 shake narrow Litho 8 Litho 8 shake narrow
	Static litho <i>Spin Speed</i>	50 ↑ 26 25 ↑ 0 0	Forward spin speed – fastest • • • Forward spin speed – slowest Reverse spin speed – slowest • • • Reverse spin speed – fastest Litho 1 (open)



Table A-6: Cyberlight DMX Assignments Mode 3

Channel	Assignment	Range %	Construct Parameter
Channel 7	Rotating Litho <i>Full Speed</i> Select the litho to rotate (forward/reverse) with this channel. Then use Channel 11 to set the rotation speed. For rotating litho position parameters select the litho position to index with this channel. Then use Channel 11 to set the rotational position (index value) from 0 to 360 degrees.	Full 98 95 91 87 83 80 76 72 68 64 61 58 54	Position 3 (open) Reverse rotate 5 Reverse rotate 4 Reverse rotate 2 Reverse rotate 1 Forward rotate 5 Forward rotate 4 Forward rotate 2 Forward rotate 1 Position 5 Position 4 Position 3 (open) Position 2 Position 1
	<i>Mspeed</i>	50 46 42 39 36 32 28 24 20 17 13 10 5 0	Reverse rotate 5 Reverse rotate 4 Reverse rotate 2 Reverse rotate 1 Forward rotate 5 Forward rotate 4 Forward rotate 2 Forward rotate 1 Position 5 Position 4 Position 3 (open) Position 2 Position 1 Position 3 (open)
Channel 8	Rotate (use with Channel 7)		For Rotating Litho rotate mode use Ch 8 to set rotate speed For Rotating Litho position mode use Ch 8 to set the index from 0 to 360 degrees
Channel 9	Focus		Focus in/out
Channel 10	Iris		Iris open/close
Channel 11	Effects Wheel <i>Full Speed</i>	Full 96 91 85 80 73 67 62 56	Effect 4 – (open) Effect 8 – cyan color corrector Effect 7 – diffusion Effect 6 – wide angle Effect 5 – magenta color corrector Effect 4 – (open) Effect 3 – yellow color corrector Effect 2 – cym tri color mosaic Effect 1 – prism
Channel 11	Effects Wheel <i>Mspeed</i>	50 44 37 33 27 21 14 8 0	Effect 8 – cyan color corrector Effect 7 – diffusion Effect 6 – wide angle Effect 5 – magenta color corrector Effect 4 – (open) Effect 3 – yellow color corrector Effect 2 – tri color mosaic (C-Y-M) Effect 1 – prism Effect 4 – (open)

Table A-6: Cyberlight DMX Assignments Mode 3

Channel	Assignment	Range %	Construct Parameter
Channel 12	Shutter <i>Strobe</i> 50 % duty cycle	Full 98 97 ↑ 1 1 0	Open Closed Strobe speed – fastest • • • Strobe speed – slowest Open Closed
Channel 13	Dim		Dim open/close
Channel 14	Motor Speed	Full ↑ 0	Speed 97 • • • Speed 1 Speed 94
Channel 15*	Control		50% fader – shutdown 25% fader – home



* - Make sure you first follow the instructions in the section titled “Accessing Control Information” on page A-2.

Channel Boundaries

This section describes the relationship between DMX address and fixture number, and explains how to mix fixtures using DMX modes 1 or 2 with DMX mode 3 on the same link.

Overview

DMX 512 protocol provides 512 channels that are divided among all the fixtures connected to the controller in a particular link. The number of channels that a fixture uses depends on the requirements and design of the fixture. In theory, you could have one fixture that uses 512 channels, two fixtures that use 256 channels, four fixtures that use 128 channels, up to 512 fixtures that use one channel each.

Each Cyberlight fixture uses a contiguous block of channels with each block having a unique starting address. The block of channels assigned to each address defines its *channel boundary*. Channel boundaries can start at any address, even or odd. The exact address depends on the fixture's addressing scheme.

Cyberlight DMX modes 1 and 2 are each on 20-channel boundaries while mode 3 is on a 15-channel boundary.

A

Correlation of Fixture Number and DMX Address

Table A-7 and Table A-8 correlate DMX mode fixture numbering to actual DMX 512 addresses.

Table A-7: 20-Channel Addresses (Modes 1 and 2)

Fixture Number:DMX Address Range	Fixture Number:DMX Address Range	Fixture Number:DMX Address Range	Fixture Number:DMX Address Range	Fixture Number:DMX Address Range
1: 1-20	6: 101-120	11: 201-220	16: 301-320	21: 401-420
2: 21-40	7: 121-140	12: 221-240	17: 321-340	22: 421-440
3: 41-60	8: 141-160	13: 241-260	18: 341-360	23: 441-460
4: 61-80	9: 161-180	14: 261-280	19: 361-380	24: 461-480
5: 81-100	10: 181-200	15: 281-300	20: 381-400	25: 481-500

Table A-8: 15-Channel Addresses (Mode 3)

Fixture Number:DMX Address Range	Fixture Number:DMX Address Range	Fixture Number:DMX Address Range	Fixture Number:DMX Address Range	Fixture Number:DMX Address Range	Fixture Number:DMX Address Range
1: 1-15	7: 91-105	13: 181-195	19: 271-285	25: 361-375	31: 451-465
2: 16-30	8: 106-120	14: 196-210	20: 286-300	26: 376-390	32: 466-480
3: 31-45	9: 121-135	15: 211-225	21: 301-315	27: 391-405	33: 481-495
4: 46-60	10: 136-150	16: 226-240	22: 316-330	28: 406-420	34: 496-511
5: 61-75	11: 151-165	17: 241-255	23: 331-345	29: 421-435	
6: 76-90	12: 166-180	18: 256-270	24: 346-360	30: 436-450	



Mixing Modes on the Same Link

High End Systems recommends that you assign all Cyberlight fixtures on a particular link to the same DMX mode. This saves you from having to remember which commands are supported by which mode for which fixture. All Cyberlight models (CLs, CXs and SVs) are compatible with all three DMX modes. The only differences in functionality are between CXs and CLs/SVs; namely, CXs do not support zoom or color mixing. A CX will simply not respond to color mixing or zoom commands.

If you do wish to mix DMX modes on a particular link, however, you need to be aware that addressing 20-channel and 15-channel fixtures in an unplanned fashion can cause wasted channels because of boundary overlapping. For example, notice in Figure A-2 that to address two 20-channel fixtures and two 15-channel fixtures in the order, 20 - 15 - 20 - 15 would waste 35 channels. (Fixture numbers 2, 5 and 6 cannot be used because address ranges used by the fixtures would overlap.)

Addressing the same fixtures in a planned order, 20 - 20 - 15 - 15, would waste only 5 channels as Figure A-3 shows.

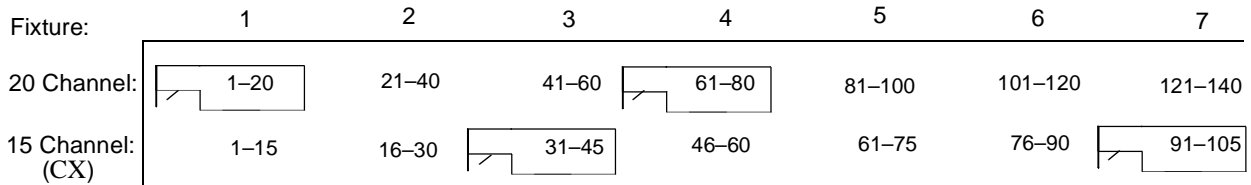

Figure A-2. Unplanned channel addressing wastes DMX addresses because of fixture boundary overlap.

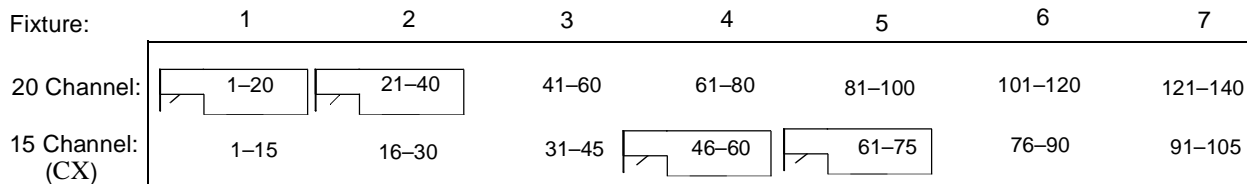

Figure A-3. Planned channel addressing wastes a minimum of DMX address space.



Appendix B Cyberlight[®] Mirror Movement Times

Use this appendix to determine the mirror movement times in seconds for the speed range of 0 to 99. Note that these values also apply to the Intellibeam and Trackspot fixtures.

Speed #	Time (sec.)	Speed #	Time (sec.)
99	0.15	54	32.62
98	0.17	53	34.08
97	0.22	52	35.57
96	0.34	51	37.09
95	0.41	50	38.65
94	0.55	49	40.23
93	0.73	48	41.85
92	0.94	47	43.50
91	1.18	46	45.19
90	1.45	45	46.90
89	1.76	44	48.65
88	2.09	43	50.43
87	2.46	42	52.2
86	2.86	41	54.09
85	3.30	40	55.96
84	3.76	39	57.87
83	4.26	38	59.81
82	4.79	37	61.78
81	5.35	36	63.78
80	5.94	35	65.82
79	6.57	34	67.89
78	7.22	33	69.99
77	7.91	32	72.12
76	8.64	31	74.28
75	9.39	30	76.48
74	10.17	29	78.71
73	10.99	28	80.97
72	11.84	27	83.26
71	12.72	26	85.59
70	13.64	25	87.95
69	14.58	24	90.33
68	15.56	23	92.76
67	16.57	22	95.21
66	17.61	21	97.69
65	18.69	20	100.21
64	19.79	19	102.76
63	20.93	18	105.34
62	22.10	17	107.95
61	23.30	16	110.60
60	24.54	15	113.28
59	25.80	14	115.98
58	27.10	13	118.73
57	28.44	12	121.50
56	29.80	11	124.31
55	31.19	10	127.14

B

Speed #	Time (sec.)	Speed #	Time (sec.)
9	130.01	4	144.84
8	132.91	3	147.90
7	135.85	2	151.00
6	138.82	1	154.13
5	141.81	0	157.28

Appendix C

Factory-Installed Wheels

This appendix shows how the static litho, rotating litho, color and effects wheels are configured by the factory when Cyberlight is shipped. The numbers shown around the outside of the wheels are the position numbers used by a controller to select that effect. For example, choosing position 5 on the CX static litho wheel (shown in Figure C-1 below) with a controller selects the “tunnel” litho.

CX static litho wheel:

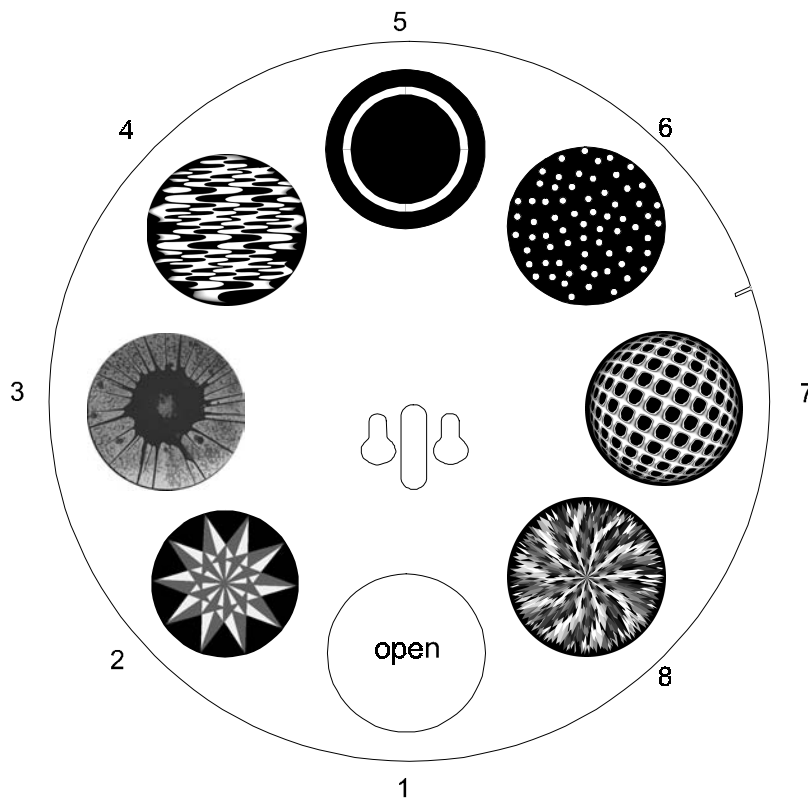

Figure C-1. Factory configuration of the CX static litho wheel.

Litho names:

1	open	5	tunnel
2	beveled star	6	indigo dots
3	indigo spin	7	network
4	groovy	8	sharp burst

CL/SV static litho wheel:

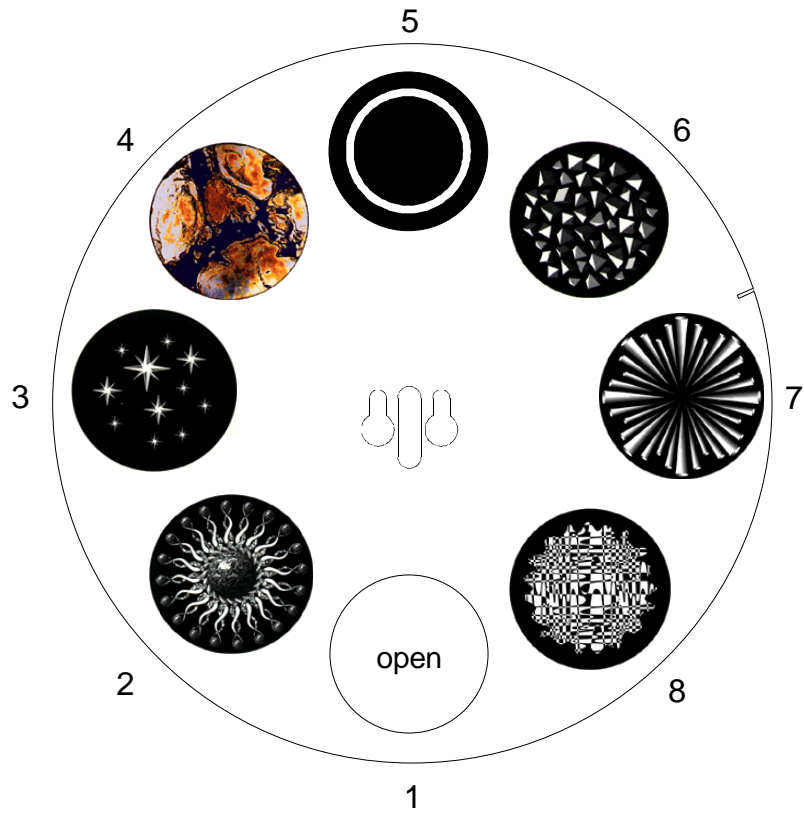
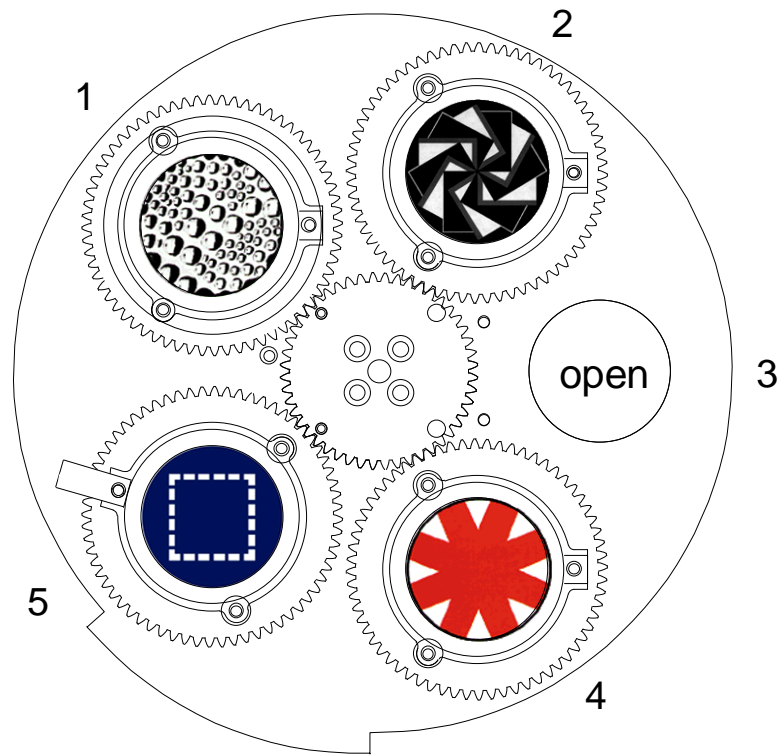

Figure C-2. Factory configuration of the CL/SV static litho wheel.

Litho names:

1	open	5	tunnel
2	alien star	6	egyptian space
3	shimmering star	7	conoid
4	indigo dye	8	disconnect

CX rotating litho wheel:



C

Figure C-3. Factory configuration of the CX rotating litho wheel.

Litho names:

1	droplets
2	paperstack
3	open
4	red wedge
5	indigo square

CL/SV rotating litho wheel:

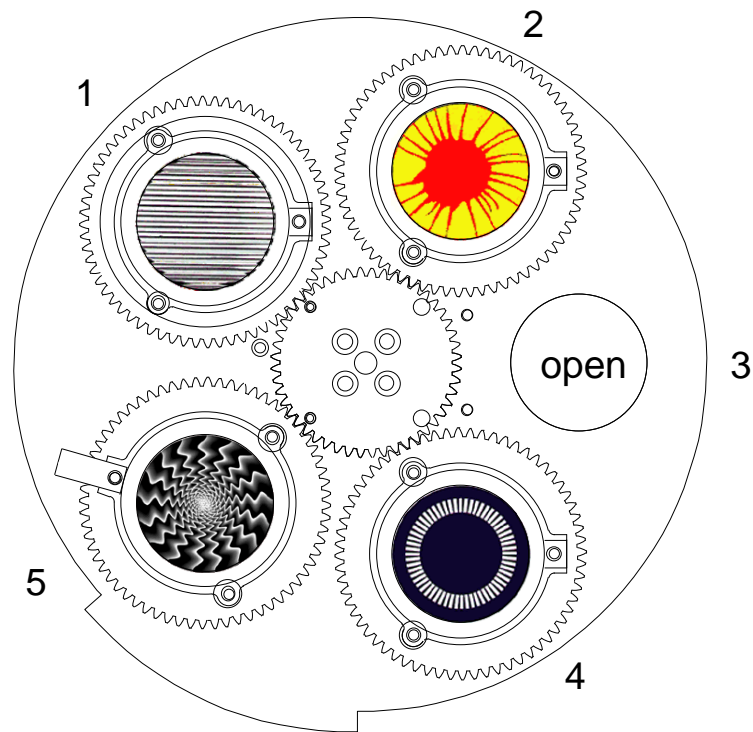

Figure C-4. Factory configuration of the CL/SV rotating litho wheel.

Litho names:

1	ribbed glass
2	psy-spin
3	open
4	indigo chiclet
5	wavy black

CX color wheel:

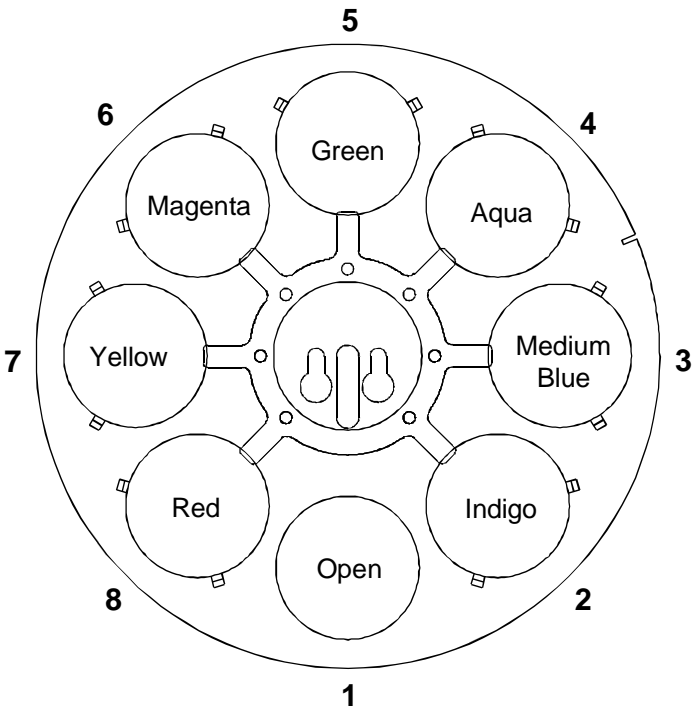

Figure C-5. Factory configuration of the CX color wheel.



CL/SV color wheel:

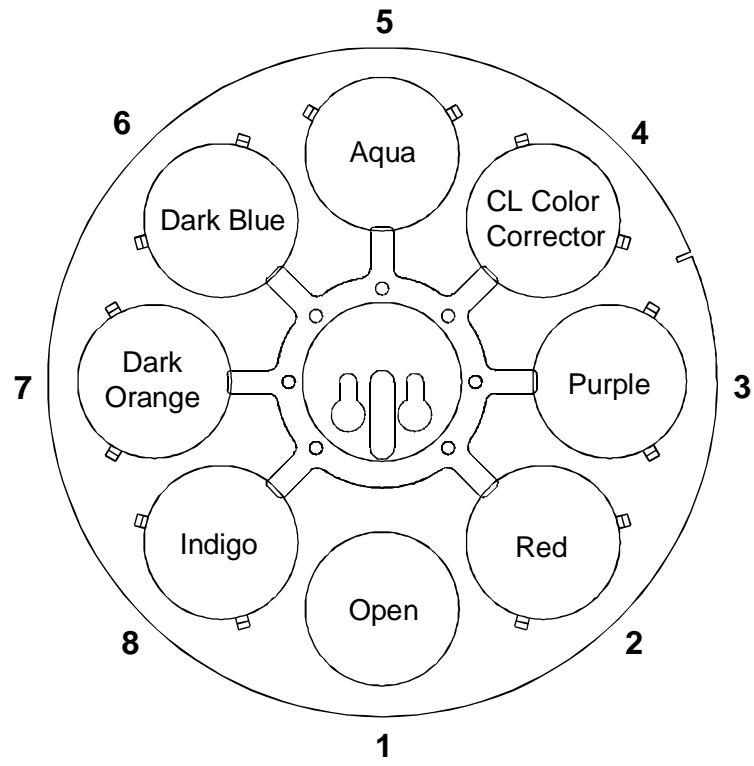

Figure C-6. Factory configuration of the CL/SV color wheel.

Effects wheel for all Cyberlight models (CX, SV and CL):

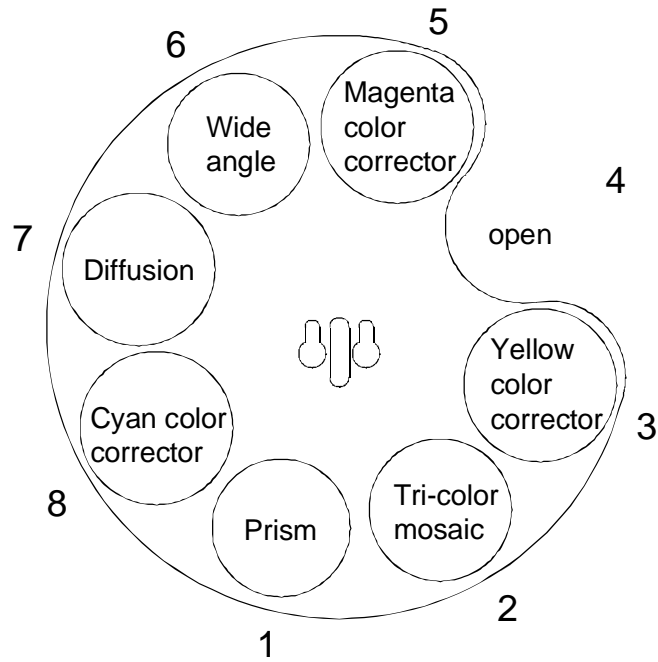

Figure C-7. Effects wheel for the CL, CX and SV models.



Appendix D

Typical Voltages Worldwide

This Appendix lists typical worldwide voltage ratings based on High End Systems Inc.'s experience. Although High End Systems believes this information to be reasonably correct to the extent of our knowledge, you should heed the Warning below before proceeding.



Warning Information in this table is subject to change. Before selecting a voltage/frequency for your Cyberlight, you should verify the correct voltage/frequency setting with a local authority. Selecting an incorrect voltage/frequency will result in an electric shock hazard and can cause injury to persons as well as damage the fixture. High End Systems can accept no responsibility for damage to your Cyberlight or other equipment caused by an incorrect voltage/frequency setting.

Continent	Country	Hz	Supply	Cyberlight Voltage Tab Setting
Africa	Algeria	50	127–220V	S7 230V / 50 Hz
	Angola	50	220V	S7 230V / 50 Hz
	Benin	50	220V	S7 230V / 50 Hz
	Bophuthatswana	50	220V	S7 230V / 50 Hz
	Botswana	50	220V	S7 230V / 50 Hz
	Burkina Faso (Upper	50	220V	S7 230V / 50 Hz
	Burundi	50	220V	S7 230V / 50 Hz
	Cameroon	50	127–220V	S7 230V / 50 Hz
	Canary Islands	50	127–220V	S7 230V / 50 Hz
	Central African	50	220V	S7 230V / 50 Hz
	Chad	50	220V	S7 230V / 50 Hz
	Congo	50	220V	S7 230V / 50 Hz
	Dahomey	50	220V	S7 230V / 50 Hz
	Djibouti	50	220V	S7 230V / 50 Hz
	Egypt	50	110–220V	S7 230V / 50 Hz
	Ethiopia	50	220V	S7 230V / 50 Hz
	Gabon	50	220V	S7 230V / 50 Hz
	Gambia	50	230V	S7 230V / 50 Hz
	Ghana	50	240V	S6 240V / 50 Hz
	Guinea	50	220V	S7 230V / 50 Hz
	Ivory Coast	50	220V	S7 230V / 50 Hz
	Kenya	50	240V	S6 240V / 50 Hz
	Lesotho	50	230V	S7 230V / 50 Hz
	Liberia	60	120V	S9 208V / 60 Hz
	Libya	50	110–115V	S8 205V / 50 Hz
	Malagasy Republic	50	127–220V	S7 230V / 50 Hz
	Malawi	50	230V	S7 230V / 50 Hz
	Mali	50	220V	S7 230V / 50 Hz
	Mauritania	50	220V	S7 230V / 50 Hz
	Mauritius	50	230V	S7 230V / 50 Hz
	Morocco	50	110–127V	S8 205V / 50 Hz
	Mozambique	50	220V	S7 230V / 50 Hz
	Namibia/ SW Africa	50	220V	S7 230V / 50 Hz
Niger	50	220V	S7 230V / 50 Hz	
Nigeria	50	230V	S7 230V / 50 Hz	
Rwanda	50	220V	S7 230V / 50 Hz	
Senegal	50	110V	S8 205V / 50 Hz	
Seychelles	50	240V	S6 240V / 50 Hz	
Senegambia	50	127V	S7 230V / 50 Hz	
Sierra Leone	50	230V	S7 230V / 50 Hz	
Somalia	50	220V	S7 230V / 50 Hz	
South Africa	50	220V	S7 230V / 50 Hz	
Sudan	50	240V	S6 240V / 50 Hz	
Swaziland	50	220V	S7 230V / 50 Hz	

D

Continent	Country	Hz	Supply	Cyberlight Voltage Tap Setting
Africa	Tanzania	50	230V	S7 230V / 50 Hz
	Togo	50	127-220V	S7 230V / 50 Hz
	Tunisia	50	127-220V	S7 230V / 50 Hz
	Uganda	50	240V	S6 240V / 50 Hz
	Upper Volta (Burkina Faso)	50	220V	S7 230V / 50 Hz
	Zaire	50	220V	S7 230V / 50 Hz
	Zambia	50	220V	S7 230V / 50 Hz
	Zimbabwe	50	220V	S7 230V / 50 Hz
Australia	Australia	50	240-265V	S6 240V / 50 Hz
	Fiji Islands	50	240V	S6 240V / 50 Hz
	Guam	60	120	S9 208V / 60 Hz
	New Caledonia	50	220V	S7 230V / 50 Hz
	New Zealand	50	230-245V	S6 240V / 50 Hz
	Papua New Guinea	50	240V	S6 240V / 50 Hz
	Solomon Islands	50	240V	S6 240V / 50 Hz
	Tahiti	60	127V	S9 208V / 60 Hz
	Tonga	50	230V	S7 230V / 50 Hz
	Western Samoa	50	230V	S7 230V / 50 Hz
Asia	Afghanistan	50/60	220V	S7 230V / 50 Hz
	Bangladesh	50	230V	S7 230V / 50 Hz
	Brunei	50	240V	S6 240V / 50 Hz
	Burma	50	230V	S7 230V / 50 Hz
	Cambodia	50	120-220V	S7 230V / 50 Hz
	China	50	220V	S7 230V / 50 Hz
	Hong Kong	50	220V	S7 230V / 50 Hz
	India	50	230V	S7 230V / 50 Hz
	Indonesia	50	127-220V	S7 230V / 50 Hz
	Japan	50/60	100-200V	S8 205V / 50 Hz
	Kazakhstan	50	220V	S7 230V / 50 Hz
	Kirgizstan	50	220V	S7 230V / 50 Hz
	Korea (North)	60	220V	S8 230V / 60 Hz
	Korea (South)	60	110-220V	S8 230V / 60 Hz
	Laos	50	220V	S7 230V / 50 Hz
	Macao	50	115-220V	S7 230V / 50 Hz
	Malaysia	50	240V	S6 240V / 50 Hz
	Myanmar	50	230V	S7 230V / 50 Hz
	Nepal	50	220V	S7 230V / 50 Hz
	Philippines	60	110-220V	S8 230V / 60 Hz
	Russia	50	127-220	S7 230V / 50 Hz
	Saah (N. Borneo)	50	240V	S6 240V / 50 Hz
	Singapore	50	230-245V	S6 240V / 50 Hz
	Sri Lanka (Ceylon)	50	230V	S7 230V / 50 Hz
	Taiwan	60	110V	S9 208V / 60 Hz
	Tajikistan	50	220V	S7 230V / 50 Hz
	Thailand	50	220V	S7 230V / 50 Hz
	Turkmenistan	50	220V	S7 230V / 50 Hz
Vietnam	50	120V	S6 240V / 50 Hz	
Central America	Anguilla	50	230V	S7 230V / 50 Hz
	Antigua (Leeward Is.)	50	230V	S7 230V / 50 Hz
	Bahamas	60	115V	S9 208V / 60 Hz
	Barbados	50	115V	S7 230V / 50 Hz
	Belize	60	110-220V	S9 208V / 60 Hz
	Bermuda	60	115V	S9 208V / 60 Hz
	Cayman Islands	60	120V	S9 208V / 60 Hz
	Costa Rica	60	120V	S9 208V / 60 Hz
	Cuba	60	115-120V	S9 208V / 60 Hz
	Dominica	60	110-220V	S9 208V / 60 Hz
	Dominican Republic	60	110V	S9 208V / 60 Hz
	El Salvador	60	115V	S9 208V / 60 Hz
	Grenada	50	230V	S7 230V / 50 Hz
	Guadeloupe	50	220V	S7 230V / 50 Hz
	Guatemala	60	115V	S9 208V / 60 Hz
	Haiti	60	110V	S9 208V / 60 Hz
	Honduras	60	110V	S9 208V / 60 Hz
	Jamaica	50	110-220V	S7 230V / 50 Hz
	Martinique	50	220V	S7 230V / 50 Hz
	Mexico	60	120V	S9 208V / 60 Hz

Continent	Country	Hz	Supply	Cyberlight Voltage Tab Setting
Central America	Monteserrat	60	230V	S8 230V / 60 Hz
	Netherland Antilles	50	110-127V	S7 230V / 50 Hz
	Nicaragua	60	120V	S9 208V / 60 Hz
	Panama	60	110-120	S9 208V / 60 Hz
	Puerto Rico	60	120V	S9 208V / 60 Hz
	St. Kitts & Nevis	60	230V	S8 230V / 60 Hz
	St. Lucia	50	240V	S6 240V / 50 Hz
	St. Vincent	50	230V	S7 230V / 50 Hz
	Trinidad & Tobago	60	115-230V	S8 230V / 60 Hz
Virgin Islands	60	120V	S9 208V / 60 Hz	
Europe	Albania	50	220-380V	S7 230V / 50 Hz
	Austria	50	220V	S7 230V / 50 Hz
	Azores	50	220V	S7 230V / 50 Hz
	Belarus	50	220V	S7 230V / 50 Hz
	Belgium	50	220V	S7 230V / 50 Hz
	Bosnia Herzegovina	50	220V	S7 230V / 50 Hz
	Bulgaria	50	220V	S7 230V / 50 Hz
	Channel Islands	50	210-240V	S6 240V / 50 Hz
	Croatia	50	220V	S7 230V / 50 Hz
	Czech Republic	50	220V	S7 230V / 50 Hz
	Denmark	50	220V	S7 230V / 50 Hz
	Estonia	50	220V	S7 230V / 50 Hz
	Faeroe Islands	50	220V	S7 230V / 50 Hz
	France	50	220V	S7 230V / 50 Hz
	Finland	50	220V	S7 230V / 50 Hz
	Germany	50	220V	S7 230V / 50 Hz
	Gibraltar	50	240V	S6 240V / 50 Hz
	Greece	50	220V	S7 230V / 50 Hz
	Greenland	50	220V	S7 230V / 50 Hz
	Hungary	50	220V	S7 230V / 50 Hz
	Iceland	50	220V	S7 230V / 50 Hz
	Ireland	50	220V	S7 230V / 50 Hz
	Isle of Man	50	240V	S6 240V / 50 Hz
	Italy	50	220V	S7 230V / 50 Hz
	Latvia	50	220V	S7 230V / 50 Hz
	Lithuania	50	220V	S7 230V / 50 Hz
	Luxembourg	50	220V	S7 230V / 50 Hz
	Macedonia	50	220V	S7 230V / 50 Hz
	Madiera	50	220V	S7 230V / 50 Hz
	Majorca Island	50	220V	S7 230V / 50 Hz
	Malta	50	240V	S6 240V / 50 Hz
	Moldova	50	220V	S7 230V / 50 Hz
	Monaco	50	220V	S7 230V / 50 Hz
	Montenegro	50	220V	S7 230V / 50 Hz
Netherlands	50	220V	S7 230V / 50 Hz	
Northern Ireland	50	230V	S7 230V / 50 Hz	
Norway	50	220-230V	S7 230V / 50 Hz	
Poland	50	220V	S7 230V / 50 Hz	
Portugal	50	220V	S7 230V / 50 Hz	
Romania	50	220V	S7 230V / 50 Hz	
Russia	50	220V	S7 230V / 50 Hz	
Serbia	50	220V	S7 230V / 50 Hz	
Slovakia	50	220V	S7 230V / 50 Hz	
Slovenia	50	220V	S7 230V / 50 Hz	
Spain	50	210-220V	S7 230V / 50 Hz	
Sweden	50	220V	S7 230V / 50 Hz	
Switzerland	50	220V	S7 230V / 50 Hz	
Ukraine	50	220V	S7 230V / 50 Hz	
United Kingdom	50	220-250V	S6 240V / 50 Hz	
Yugoslavia	50	220V	S7 230V / 50 Hz	
Middle East	Armenia	50	220V	S7 230V / 50 Hz
	Azerbaijan	50	220V	S7 230V / 50 Hz
	Abu Dhabi	50	240V	S6 240V / 50 Hz
	Afghanistan	50	220V	S7 230V / 50 Hz
	Bahrain	50	230V	S7 230V / 50 Hz
	Cyprus	50	240V	S6 240V / 50 Hz
	Georgia	50	220V	S7 230V / 50 Hz



Continent	Country	Hz	Supply	Cyberlight Voltage Tap Setting
Middle East	Iran	50	220V	S7 230V / 50 Hz
	Iraq	50	220V	S7 230V / 50 Hz
	Israel	50	230V	S7 230V / 50 Hz
	Jordan	50	220V	S7 230V / 50 Hz
	Kuwait	50	240V	S6 240V / 50 Hz
	Lebanon	50	110-220V	S7 230V / 50 Hz
	Muscat	50	240V	S6 240V / 50 Hz
	Oman	50	240V	S6 240V / 50 Hz
	Pakistan	50	230V	S7 230V / 50 Hz
	Qatar	50	240V	S6 240V / 50 Hz
	Saudi Arabia	60	127-220V	S8 230V / 60 Hz
	Sudan	50	240V	S6 240V / 50 Hz
	Syria	50	220V	S7 230V / 50 Hz
	Turkey	50	220V	S7 230V / 50 Hz
	United Arab Emirates	50	220V	S7 230V / 50 Hz
Yemen	50	220V	S7 230V / 50 Hz	
North America	Canada	60	115V	S9 208V / 60 Hz
	United States	60	120V	S9 208V / 60 Hz
South America	Argentina	50	220V	S7 230V / 50 Hz
	Bolivia	50	110V	S7 230V / 50 Hz
	Brazil	60	110-127-	S8 230V / 60 Hz
	Chile	50	220V	S7 230V / 50 Hz
	Columbia	60	110-120V	S9 208V / 60 Hz
	Ecuador	60	110-120V	S9 208V / 60 Hz
	French Guiana	50	220V	S7 230V / 50 Hz
	Guyana	60/50	110V/60 &	S9 208/60 Hz & S6 240V/50 Hz
	Paraguay	50	220V	S7 230V / 50 Hz
	Peru	60	220V	S8 230V / 60 Hz
	Suriname	60	110-127V	S9 208V / 60 Hz
	Uruguay	50	220V	S7 230V / 50 Hz
	Venezuela	60	120V	S9 208V / 60 Hz

Appendix E

Important Safety Information

WARNING: For Continued Protection Against Fire

1. This equipment is designed for use with Philips type MSR1200 or MSD1200, 1200 watt lamp only. Use of any other type lamp may be hazardous and will void the warranty.
2. Do not mount on a flammable surface.
3. Maintain minimum distance of 1.0 meter (3.28 feet) from combustible materials.
4. Replace fuses only with the specified type and rating.
5. Observe minimum distance to lighted objects of 1.0 meter (3.28 feet).
6. This equipment for connection to branch circuit having a maximum overload protection of 20 A.

WARNING: For Continued Protection Against Electric Shock

1. If this equipment was received without a line cord plug, attach the appropriate line cord plug according to the following code:
 - **Brown–live**
 - **Blue–neutral**
 - **Green/yellow–earth**
2. As the colours of the cores in the mains lead of this equipment may not correspond with the coloured markings identifying the terminals in your plug, proceed as follows:
 - the core which is coloured green and yellow must be connected to the terminal in the plug which is marked with the letter “E” or by the earth symbol , or coloured green or green and yellow.
 - the core which is coloured blue must be connected to the terminal which is marked with the letter N or coloured black.
 - the core which is coloured brown must be connected to the terminal which is marked with the letter L or coloured red.
3. This equipment must be earthed.
4. Disconnect power before re-lamping or servicing.



5. Equipment suitable for dry locations only. Do not expose this equipment to rain or moisture.
6. Refer servicing to qualified personnel; no user serviceable parts inside.
7. Class I equipment - this fixture employs a grounded type receptacle and is not intended for connection to a two wire, ungrounded source of supply.

WARNING: For Continued Protection Against Exposure To Excessive Ultraviolet (UV) Radiation

1. Do not operate this equipment without complete lamp enclosure in place or if shields, lenses, or ultraviolet screens are damaged.
2. Change shields, lenses, or ultraviolet screens if they have become visibly damaged to such an extent that their effectiveness is impaired, for example by cracks or deep scratches.
3. Never look directly at the lamp while lamp is on.

WARNING: For Continued Protection Against Injury To Persons

1. Use secondary safety cable when mounting this fixture.
2. CAUTION: Hot lamp may be an explosion hazard. Do not open for 5 minutes after switching off. wear eye and hand protection when re-lamping.
3. Equipment surfaces may reach temperatures up to 62° C (144° F). Allow 10 minutes for cooling before handling.
4. Change the lamp if it becomes damaged or thermally deformed.

APPENDICE E

IMPORTANTES INFORMATIONS SUR LA SÉCURITÉ

MISE EN GARDE: Pour Une Protection Permanente Contre Les Incendies

1. Cet appareil est conçu pour être exclusivement utilisé avec des lampes de 1200 watts MSR 1200 ou MSD 1200. L'usage d'autres lampes peut être risqué et annulera la garantie.
2. Ne pas monter les lampes sur une surface inflammable.
3. Maintenir à une distance minimum de 1.0 mètre de matières inflammables.
4. Ne remplacer les fusibles qu'avec des modèles et valeurs assignées recommandés.
5. Respecter une distance minimum de 1.0 mètre par rapport aux objets éclairés.
6. Cet appareil de connexion au circuit de dérivation comporte une protection contre les surcharges de 20A.

MISE EN GARDE: Pour Une Protection Permanente Contre Les Chocs Électriques

1. Assembler le câble électrique conformément aux instructions du manuel.
2. Déconnecter le courant avant de changer les lampes ou d'effectuer des réparations.
3. Cet équipement doit être uniquement utilisé dans des endroits secs. Ne pas l'exposer à la pluie ou l'humidité.
4. À l'intérieur de l'équipement il n'y a pas de pièces remplaçables par l'utilisateur. Confiez l'entretien à un personnel qualifié.
5. Equipement de Classe I - Cette pièce fixe utilise une prise de courant branché à la terre et elle ne doit pas être branché à une source électrique, non reliée à la terre, à double fil.

E

MISE EN GARDE: Pour Une Protection Permanente Contre Des Expositions Excessives Aux Rayons Ultra Violets (UV)

1. Ne pas utiliser cet appareil si le boîtier de la lampe n'est pas complètement fixé ou si les blindages, lentilles, ou écrans ultraviolets sont endommagés.
2. Changer les blindages ou les écrans ultraviolets s'ils sont visiblement endommagés au point que leur efficacité aient été altérée, par exemple par des fissures ou de profondes égratignures.
3. Ne jamais regarder directement la lampe quand celle ci est allumée.

MISE EN GARDE: Pour Une Protection Permanente Contre Les Blessures Corporelles

1. Lors de l'assemblage ou du montage, utiliser un câble de sécurité secondaire.
2. AVERTISSEMENT: les lampes chaudes comportent un risque d'explosion. Après l'avoir éteinte, attendre 5 minutes avant de la dégager. Lors du remplacement de la lampe, porter des lunettes, et des gants de protection.
3. Les surfaces de l'appareil peuvent atteindre des températures de 62° C. Laisser refroidir pendant 10 minutes avant la manipulation.
4. Changer la lampe si elle est endommagée ou thermiquement déformé.

ANHANG E

WICHTIGE HINWEISE FÜR IHRE SICHERHEIT

WARNUNG: Zum Schutz vor Brandgefahr

1. Dieses Gerät darf nur mit 1200 Watt Lampen vom Typ MSR 1200 oder MSD 1200 von Philips verwendet werden. Die Verwendung von Lampen eines anderen Typs kann gefährlich sein und ein Erlöschen der Garantieansprüche zur Folge haben.
2. Das Gerät nie auf einer feuergefährlichen Fläche montieren.
3. Stets einen Mindestabstand von 1 Meter zu brennbaren Materialien einhalten.
4. Zum Ersatz nur Sicherungen verwenden, die dem vorgeschriebenen Typ und Nennwert entsprechen.
5. Einen Mindestabstand von 1 Meter zu den angestrahlten Objekten einhalten.
6. Dieses Gerät darf nur an eine Zweigleitung mit einem Überlastungsschutz von höchstens 20 A angeschlossen werden.

WARNUNG: Zum Schutz Gegen Gefährliche Körperströme

1. Bei der Installation des Netzkabels am Lampensockel folgen Sie bitte Anweisungen in diesem Handbuch.
2. Vor dem Austauschen von Lampen oder vor Wartungsarbeiten stets den Netzstecker ziehen.
3. Diese Geräte sind nur zum Einbau in trockenen Lagen bestimmt und müssen vor Regen und Feuchtigkeit geschützt werden.
4. Servicearbeiten sollten nur von Fachpersonal ausgeführt werden. Das Gerät enthält keine wartungsbedürftigen Teile.
5. Dieses Gerät gehört zur Klasse 1 - Dieser Beleuchtungskörper verwendet eine geerdete Fassung und sollte nicht an eine zweipolige, ungeerdete Stromversorgung angeschlossen werden.



WARNUNG: Zum Schutz Gegen Übermäßige Ultraviolett (UV)-bestrahlung

1. Benutzen Sie dieses Gerät nur, wenn das komplette Lampengehäuse fest eingebaut ist; ebenfalls dürfen keine der Schutzabdeckungen, Linsen oder der UV-Schutz Beschädigungen aufweisen.
2. Die Schutzabdeckungen, Linsen und der UV-Schutz müssen ausgewechselt werden, wenn sie sichtlich dermaßen beschädigt sind, daß sie ihre Wirksamkeit einbüßen, z.B. infolge von Rissen oder tiefen Kratzern.
3. Nie direkt in die eingeschaltete Lampe schauen.

WARNUNG: Zum Schutz Vor Verletzungen

1. Verwenden Sie bei der Installation des Beleuchtungskörpers ein zusätzliches Sicherheitskabel.
2. **VORSICHT:** Bei einer heißen Lampe besteht Explosionsgefahr. Nach dem Abschalten der Netzspannung sollten Sie etwa 5 Minuten warten, bevor Sie das Lampengehäuse öffnen. Schützen Sie beim Auswechseln der Lampen Ihre Hände und tragen Sie eine Schutzbrille.
3. Die Oberflächen des Gerätes können Temperaturen bis zu 62° C erreichen. Vor dem Anfassen stets 10 Minuten lang abkühlen lassen.
4. Falls die Lampe beschädigt oder durch Wärmeeinwirkung verformt ist, muß sie ausgewechselt werden.

APÉNDICE E

INFORMACIÓN IMPORTANTE DE SEGURIDAD

ADVERTENCIA: Para Protección Continua Contra Incendios

1. Se ha diseñado este equipo para usarse con lámpara tipo philips MSR1200 ó MSD 1200, 1200 vatios. El uso de otro tipo de lámpara puede resultar peligroso e invalidará la garantía.
2. No monte el equipo sobre una superficie inflamable.
3. Mantenga una distancia mínima de materiales combustibles de 1,0 metro.
4. Cambie los fusibles únicamente por otros que sean del tipo y la clasificación especificadas.
5. Observe una distancia mínima a objetos iluminados de 1,0 metro.
6. Este equipo debe conectarse a un circuito derivado que tenga una protección máxima contra las sobrecargas de 20 A.

ADVERTENCIA: Para La Protección Continua Contra Electrocuiones

1. Ensamble la tapa del cordón de alimentación según las instrucciones del manual.
2. Desconecte el suministro de energía antes de recambiar lámparas o prestar servicio de reparación.
3. Este equipo se adecua a lugares secos solamente. no lo exponga a la lluvia o humedad.
4. Derive el servicio de reparación de este equipo al personal calificado. El interior no contiene repuestos que puedan ser reparados por el usuario.
5. Equipo de Clase 1. Este aparato emplea un enchufe hembra del tipo unido a tierra, y no tiene por finalidad conectarse a una fuente de alimentación bifilar y sin puesta a tierra.



ADVERTENCIA: Para Protección Continua Contra La Exposición A Radiación Ultravioleta (UV) Excesiva

1. No opere este equipo sin tener colocada en su lugar la caja protectora completa de la lámpara o bien, si el blindaje, los lentes o las pantallas ultravioletas están dañadas.
2. Cambie el blindaje, los lentes o las pantallas ultravioleta si nota una avería visible, a tal grado que su eficacia se vea comprometida, por ejemplo, en el caso de grietas o rayaduras profundas.
3. Jamás mire directamente a la lámpara en tanto ésta esté encendida.

ADVERTENCIA: Para Protección Continua Contra Lesiones Corporales

1. Use cable secundario de seguridad al montar este aparato.
2. PRECAUCIÓN: Una lámpara caliente puede constituir un peligro de explosión. No la abra por 5 minutos luego de haberla apagado. Lleve puestos un protector ocular y guantes al recambiar lámparas.
3. Las superficies del equipo pueden alcanzar temperaturas máximas de 62 grados centígrados. Deje que se enfríen por 10 minutos antes de tocarlas.
4. Cambie la lámpara si ésta se avería o deforma por acción térmica.

APPENDICE E

IMPORTANTI INFORMAZIONI PER LA SICUREZZA

AVVERTENZA: Per La Prevenire Di Incendi

1. Questo apparecchio e' stato disegnato per l'impiego esclusivo di lampade tipo MSR 1200 o MSD 1200 Watt. L'impiego di altri tipi di lampade potrebbe essere pericoloso e rende nulla la garanzia.
2. Non montare su superfici infiammabili.
3. Mantenere l' apparecchio ad una distanza minima di 1 metro (3.28 piedi) da materiali combustibili.
4. Rimpiazzare I fusibili utilizzando solo quelli del tipo e della portata (Corrente nominale/velocita') specificata.
5. Mantenere una distanza minima da oggetti illuminati di 1 metro (3.28 Piedi).
6. Questo apparecchio deve essere collegato alla rete con ínterruttore automatico 20A.

AVVERTENZE: Per La Prevenzione Costante Di Scosse Elettriche

1. Assemblare il terminale del cavo seguendo il manuale delle istruzioni.
2. Scollegare la corrente prima di sostituire la lampada o eseguire la riparazione.
3. Questo apparecchio e' adatto ad ambienti secchi e non deve essere esposto ad agenti atmosferici o ad umidita`.
4. Per qualsiasi riparazione rivolgersi a personale specializzato. L' utente non deve riparare alcuna parte interna dell'apparecchio.
5. Apparecchio di classe I - questo apparecchio e' fornito di presa bipolare + terra e non deve essere collegato a rete sprovvista di terra.



AVVERTENZE: Per La Protezione Costante Da Eccessiva Esposizione Agli Ultravioletti

1. Non azionare questo apparecchio in caso la lampada non sia schermata o schermi, lenti o filtri UV siano danneggiati.
2. Cambiare schermi, lenti o filtri UV in caso siano visibilmente danneggiati al punto di invalidare la loro efficacia, per esempio da spaccature o da profondi graffi.
3. Non guardare direttamente la lampada se accesa.

AVVERTENZE: Per La Prevenzione Costante Di Danni Fisici Alle Persone

1. Montare l'apparecchio usando un cavo secondario di sicurezza.
2. **ATTENZIONE:** La lampada calda puo' esplodere. Non aprire prima di 5 minuti dal suo spegnimento. Usare protezioni per le mani e per gli occhi prima di cambiare la lampada.
3. Le superfici dell'apparecchio possono raggiungere una temperatura di 62 gradi centigradi (144 Gradi F). Lasciare raffreddare 10 minuti prima di maneggiare.
4. Cambiare la lampada in caso si danneggi o deformi per le alte temperature.

Glossary

Additive color mixing

The creation of colors by superimposing red, green and blue light sources. The intensities of red, green and blue light determine the resulting color. This method is commonly used in TVs and projection TV/video devices. Additive color mixing done in this way is also called the RGB (red-green-blue) color model.

See also “Subtractive color mixing”.

Block addressing

The Cyberlight is a block-addressed fixture; that is, you do not address it at an arbitrary DMX starting address *per se*, but rather at a *channel boundary*. There are two channel boundaries you can select: 15-channel and 20-channel. If you choose to control your Cyberlight on a 20-channel boundary, for example, each fixture takes up a contiguous *block* of 20 DMX channels. The more channels per fixture, the more features you can control.

See also “Fixture number”.

Central access door

Typically the most commonly-opened door on Cyberlight, where the color, effects, rotating and static litho wheels may be accessed. Figure 1-2 on page 1-11 shows all three Cyberlight access doors.

Channel boundary

The first address of a fixture’s block of addresses. For example, a Cyberlight set for fixture number 2 in 20-channel DMX mode 1 or 2 would have a channel boundary at DMX channel 21.

See also “Block addressing” and “Fixture number”.

Color temperature

A term used to describe the balance or content of each spectral component of white light.

Color temperature, in turn, relies on the concept of the *black body*. A black body is a theoretical object that absorbs all of the energy that contacts it. Heating a black body causes it to emit radiation. When the spectral composition of a black body matches the spectral composition of a white light source, the temperature of the black body (in degrees Kelvin) is the color temperature of the light source.

For example, a light source that is rated at 5600° Kelvin (such as the light source used in Cyberlight) matches the radiation of a black body heated to 5600° Kelvin.

Because not all light sources exhibit a smooth spectral power distribution, color temperature is an approximate measure of a lamp’s spectral output.

Constructs

Features of the fixture (such as color mixing, lithos, rotating lithos, color wheel, iris, frost and shutter). Constructs can be used by a controller to program your overall show.

Dichroic

A *dichroic* (from Greek, meaning “two-color”) filter achieves a richly-saturated color without using any pigmented (colored) materials. In simple terms, it achieves this effect by either reflecting or “cancelling out” through destructive interference all but a narrow range of the light spectrum.

The “dichroic” name refers to the fact that one color (or set of colors) is reflected or cancelled out, and one color is allowed to be transmitted through the dichroic filter.

The dichroics used in Cyberlight are all manufactured at the High End Systems Optical Coating and Assembly Laboratory in Austin, Texas. They are made from a base of Pyrex[®]-like glass material coated with multiple, microscopic layers of specialized materials separated by junctions that either transmit or reflect certain wavelengths of light, accounting for the resulting color.

Dichroic filters offer a number of advantages over traditional gel filters: since they are made of Pyrex-like glass and absorb almost no heat themselves, they theoretically have no failure mechanism; they transmit more light than gels; and their resultant colors are more richly-saturated than is possible with a gel.

Dichroics are currently used for all Cyberlight colored lithos, color mixing flags, effects and of course the color wheel dichroic filters. Before installing a dichroic or litho in Cyberlight, make sure you read the section titled “Removing and Installing Rotating Lithos” on page 3-19 and the section titled “Replacing Dichroics/Lithos in the Color Wheel or the Static Litho Wheel” on page 3-22.

See also “Litho”.

DMX 512 control protocol

DMX 512 is a standard method of controlling lighting fixtures and other devices (such as lasers and hazers). Developed by the United States Institute of Theatre Technology (USITT), DMX 512 is supported by leading entertainment industry equipment manufacturers, such as High End Systems.

DMX 512 (*D* for *digital*, *MX* for *multiplex* and *512* is the number of channels per link) is a reliable, efficient and well-understood method of controlling lighting devices. Its strength lies in the ability to control a large number of different types of devices made by various vendors on the same link using any DMX-compatible controller.

See also “LWR control protocol”.

DMX address

The DMX 512 protocol allows a total of 512 addresses to be used on a particular link. (A *link* is a group of devices connected on a daisy-chain of XLR cabling.) You need to assign a unique fixture number to each Cyberlight you wish to respond independently to control commands.

Multiple fixtures can be assigned the same address if you wish them all to respond to control commands in the same way.

For example, suppose you have 12 Cyberlight fixtures on one link. You want six of them to operate independently of each other and the other six to operate in exactly the same way. You need to assign each of the six independently-operating Cyberlight fixtures a unique fixture number, but you can assign a single fixture number to the other six, for a total of seven fixture numbers.

DMX modes

You can use DMX 512 protocol to control the Cyberlight in three different modes. The three DMX modes available for your Cyberlight provide three different levels of control and flexibility, and can be used with CLs, SVs, and CXs. Mode 1 is 20-channel standard control; mode 2 is enhanced 20-channel control, and mode 3 is 15-channel control. For more information on all three modes, see Appendix A.

Fixture number

Because the Cyberlight is a block-addressed fixture, you do not access it using an arbitrary DMX starting address. Instead, you can choose between 20-channel and 15-channel access (see Appendix A). Thus, the concept of fixture number can be substituted for the actual DMX channel.

For example, suppose you have chosen to control the Cyberlight using DMX mode 2, which is a 20-channel mode. Fixture number 1 occupies DMX addresses 1 through 20; fixture 2 occupies DMX addresses 21 through 40, and so on. A complete listing of how fixture numbers correlate to DMX addresses can be found in Table A-7 on page A-18.

Lamp box access door

This door provides access to the Cyberlight lamp, infrared filter, reflector and other components. Figure 1-2 on page 1-11 shows all three Cyberlight access doors.

Lamp strikes

The number of times the lamp has been illuminated. Once the lamp is “switched on”, whether it is illuminated continuously for one second or one minute, it counts as one strike.

Litho

A litho has a pattern etched on it (some lithos are also textured), as the name “LithoPatterns” suggests. All LithoPatterns are designed and manufactured at the High End Systems dichroic lab in Austin, Texas. There are currently a large number of available lithos, including LithoPatterns, Art Glass, Psy-Dye and Special Effects. See the section titled “Optional Accessories” on page 1-7 for ordering information.

A dichroic process is used to color all lithos.

See also “Dichroic”.

Luminaire

Synonymous with “fixture”.

LWR control protocol

The native control protocol for Cyberlight, LWR offers all the features of DMX 512 plus it gives you the ability to perform software uploads using a High End Systems Link Card or the Cyberlight Upload Module.

MSR/MSD

MSR stands for *Medium Source Rare Earth* and describes the family of arc lamps used in the Cyberlight. Rare earth elements (such as Dysprosium and Holmium) are added to metal halide to give the lamp a more continuous spectrum.

MSD stands for *Medium Source Daylight*. (“Daylight” is a reference to the fact that the lamp has roughly the same color temperature as ordinary sunlight.) The MSD lamp has basically the same composition and the same color temperature as the MSR lamp, but it has a lower light output and longer life.

See also “Color temperature”.

Strikes

See “Lamp strikes”.

Subtractive color mixing

The creation of colors by filtering out (*subtracting*) certain wavelengths from a typically white (multi-wavelength) light source. For example, putting a magenta filter in the path of a white light source subtracts green light. This is the color mixing model used in Cyberlight. Typically, the filters used in a subtractive color mixing system are cyan, yellow and magenta; thus, this is usually referred to as the CYM color mixing model.

See also “Additive color mixing”.

Terminator

A terminator is a resistor inside an XLR connector. It is used to prevent the analog signal from continuously “echoing” up and down the data link. A terminator must be used on the last device in every DMX link. Instructions for constructing a terminator can be found in the section titled “Terminators” on page 2-7.

INDEX

A

Accessories 1-7
Adjustments
 mechanical zoom lens 3-23
 mirror head 3-24 to 3-25
 yoke 3-26
AF1000 2-3
Alignment knobs. *See* Lamp, installing or replacing
Anti-reflective glass 3-6

B

Barrel. *See* Truss
Batten. *See* Truss

C

Cabling
 constructing 2-6 to 2-7
 ordering 1-7
 pinouts 2-6, 2-7
 safety 1-7, 2-10
 specifications 1-5
 terminators 2-7
C-clamps 2-10
 ordering 1-7
Center access door 1-11
Channel boundaries A-18 to A-19
CL 1-6
Clamps 2-10
Cleaning
 dichroics 3-7 to 3-10
 fans 3-3
 flags, reflector and infrared filter 3-10 to 3-14
 lithos 3-7 to 3-10
 mirror, lenses, motor and iris 3-4 to 3-6
 outer surfaces 3-3

 rotating lithos 3-14
 wheels and sensors 3-7 to 3-10
Color mixing plate 3-12
Color wheel 3-7
 factory configuration
 CL/SV C-6
 CX C-5
 ordering custom dichroics 1-7
 replacing dichroics 3-22
 SV dichroic substitution 1-19 to 1-22
Control. *See* DMX
CTO color correction filter 1-19
Customer Service intro-4
CX
 drawing of 1-6
 mechanical zoom lens 3-23
Cyberlight
 accessories 1-7
 adjustments
 mechanical zoom lens 3-23
 mirror head 3-24 to 3-25
 yoke 3-26
 cabling
 constructing 2-6 to 2-7
 ordering 1-7
 pinouts 2-7
 terminators 2-7
 center access door 1-11
 channel boundaries A-18 to A-19
 CL 1-6
 clamps 2-10
 cleaning
 fans 3-3
 flags, reflector and infrared filter 3-10 to 3-14
 internal components 3-4 to 3-14
 mirror, lenses, motor and iris 3-4 to 3-6
 outer surfaces 3-3
 rotating lithos 3-14
 wheels and sensors 3-7 to 3-10
 color wheel
 CL/SV C-6
 CX C-5
 control. *See* DMX
 CX 1-6

- DIP switches
 - address A-2
 - personality 1-22 to 1-26
- DMX or LWR control 2-2
- effects wheel C-7
- features intro-1 to intro-3
- fixture number 2-4 to 2-5, A-18 to A-19
- front fan access door 1-11
- fuses 3-18
- hanging fixtures. *See* Cyberlight, mounting fixtures
- homing 1-18
- info LED 1-24 to 1-25
 - examples 1-25
- lamp
 - information counter 1-18
 - installing or replacing 1-16 to 1-17
 - ordering 1-7
- lamp box access door 1-11
- LED descriptions 1-27
- maintenance
 - (*see also* Maintenance)
 - adjustments 3-23 to 3-26
 - cleaning internal components 3-4 to 3-14
 - general 3-2
 - replacing parts 3-15 to 3-22
- models 1-6
- mounting fixtures 2-9 to 2-11
- pan invert 1-26
- pan/tilt swap 1-26
- power
 - ON and OFF 1-29
 - power cord cap 1-9 to 1-10
 - setting voltage 1-10 to 1-14
 - specifications 1-4
 - switch 1-29
 - voltage 1-24
- power supply board 1-13
- QC plate 1-8
- replacing
 - dichroics/lithos 3-22
 - lamp 1-16 to 1-18
 - power supply fuses 3-15 to 3-18

- rotating lithos 3-19 to 3-21
- rotating litho wheel
 - CL/SV C-4
 - CX C-3
- safety cables 2-10
- self-test 1-23
- setup mode 1-23
- specifications
 - cabling 1-5
 - electrical 1-4
 - physical 1-3
 - safety 1-4
 - safety standards 1-4
- static litho wheel
 - CL/SV C-2
 - CX C-1
- SV 1-6
 - drawing of 1-6
 - substituting dichroics 1-19 to 1-22
- tilt invert 1-26
- troubleshooting 2-12 to 2-17
- version number 1-24
- voltage 1-24
- yoke
 - adjusting 3-26
 - installing 1-14 to 1-15

Cyberlight LCD controller 1-7, 2-2

D

- Dichroic intro-2
 - cleaning 3-7 to 3-10
 - ordering 1-7
 - replacing 3-22
 - substituting in SV 1-19 to 1-22
- Dim flags 3-14
- DIP switches
 - address A-2
 - personality 1-22 to 1-26
- DMX
 - (*see also* LWR protocol)
 - channel boundaries A-18 to A-19
 - description 2-2

- fixture number
 - correlated to DMX address A-18 to A-19
 - mode 2 A-7
 - mode 3 A-13
- linking devices 2-8
- modes
 - description 2-2
 - mixing modes 1, 2 and 3 A-20
 - mode 1 A-3 to A-6
 - mode 2 A-7 to A-12
 - mode 3 A-13 to A-17
- multiple High End Systems fixtures 2-3
- procedure 2-3 to 2-4, A-2 to A-17
- selecting DMX or LWR protocol 2-2
- software uploads A-1

DMX 512. *See* DMX

DMX address. *See* DMX and Fixture number

Dousing. *See* Dim flags *and* Features

E

- Effects wheel 3-7
 - factory configuration C-7
- EIA RS-485 2-6

F

- Failure. *See* Troubleshooting
- Fan LED description 1-27
- Fan power connectors 3-12
- Fans, cleaning 3-3
- Features intro-1 to intro-3
- Firmware. *See* Software
- Fixed litho wheel 3-7
- Fixture number 2-4 to 2-5
- Focusing lens 3-5
- Front fan access door 1-11
- Fuse specifications 3-18

G

Gobos. *See* Lithos

H

Hanging fixtures. *See* Mounting fixtures

Heat filter. *See* Infrared filter.

Help intro-4

Help (*see also* Troubleshooting)

Homing 1-18

Homogenizing frost filter 1-19

I

Info LED 1-24 to 1-25

- description 1-27

- examples 1-25

Information counter (lamp) 1-18

Infrared filter 3-13

Installing

- MSR 1200 lamp 1-16 to 1-17

- rotating lithos 3-19 to 3-21

- substitute SV dichroics 1-19 to 1-22

- yoke 1-14 to 1-15

Intellabeam 2-2

K

Keyhole slots 3-8, 3-10

L

Lamp

- hours 1-24

- information counter 1-18

- installing or replacing 1-16 to 1-17

- ordering 1-7

- replacing 1-16 to 1-18
- strikes 1-24
- voltage 1-24
- Lamp alignment knobs. *See* Lamp, installing or replacing
- Lamp box access door 1-11
- Lamp LED description 1-27
- Lampholder. *See* Lamp, replacing
- LEDs
 - description 1-27
 - info 1-24 to 1-25
 - examples 1-25
- Line cord 1-9 to 1-10
- Linking fixtures 2-8
- LithoPatterns 3-19
 - ordering 1-7
- Lithos
 - accessories 1-7
 - cleaning 3-7 to 3-10
 - ordering 1-7
 - replacing 3-19 to 3-22
- Luminaire intro-1
- LWR protocol
 - description 2-2
 - implementing 2-3 to 2-5
 - software uploads A-1

M

- Maintenance
 - cleaning infrared filter, reflectors, and flags 3-10 to 3-14
 - cleaning mirror, lenses, motors and iris 3-4 to 3-6
 - cleaning the fans 3-3
 - cleaning wheels and sensors 3-7 to 3-10
 - general 3-2
 - installing rotating lithos 3-19 to 3-21
 - replacing color mixing flags 3-22
 - replacing dichroics/lithos 3-22
 - replacing power supply fuses 3-15 to 3-18
 - replacing rotating lithos 3-19 to 3-21

- Mechanical zoom lens 3-23
- Mirror head deviation 3-24 to 3-25
- Model numbers 1-3
- Models 1-6
- Modes. *See* DMX, modes
- Motor LED description 1-27
- Mounting fixtures 2-9 to 2-11
- MSD. *See* MSR 1200 lamp
- MSR 1200 lamp
 - hours 1-24
 - information counter 1-18
 - installing or replacing 1-16 to 1-17
 - LED description 1-27
 - ordering 1-7
 - strikes 1-24
 - voltage 1-24

O

- Optical sensors 3-7
- Optimizing MSR 1200 lamp. *See* Lamp, installing or replacing
- Optional accessories 1-7

P

- Pan invert 1-26
- Pan/tilt swap 1-26
- Parabolic reflector. *See* Reflector
- Power
 - fuse specifications 3-18
 - power cord cap 1-9 to 1-10
 - replacing fuses 3-15 to 3-18
 - setting voltage 1-10 to 1-14
 - specifications 1-4
 - switch 1-29
 - turning ON and OFF 1-29
- Power lens 3-5
- Power supply board 1-13
- Problems. *See* Troubleshooting

Q

Quality Control (QC) plate 1-8

R

Recv LED description 1-27

Reflector 3-13

Replacing

dichroics 3-22

dichroics/lithos 3-22

lithos 3-19 to 3-22

MSR 1200 lamp 1-16 to 1-18

power supply fuses 3-15 to 3-18

rotating lithos 3-19 to 3-21

Rotating litho wheel

factory configuration

CL/SV C-4

CX C-3

ordering lithos 1-7

removing and cleaning lithos 3-14

removing and installing lithos 3-19 to
3-21

S

Safety

of fixture mounting 2-9

specifications 1-4

standards 1-4

Safety cables 2-10

ordering 1-7

Self-test 1-23

Sensors 3-7

Setting 1-22

Setting voltage 1-10 to 1-14

Setup mode 1-23

Shutter. *See* Dim flags.

Software

uploading A-1

version number 1-24

Specifications

cabling 1-5

electrical 1-4

physical 1-3

power supply fuses 3-18

safety standards 1-4

Static litho wheel

factory configuration

CL/SV C-2

CX C-1

ordering lithos 1-7

replacing lithos 3-22

SV

drawing of 1-6

substituting dichroics 1-19 to 1-22

Switches. *See* DIP switches

T

Technical support intro-4

Terminators 2-7

Testing the fixture 1-23

Tilt invert 1-26

Trackspot 2-2

Troubleshooting 2-12 to 2-17

Truss 2-10

U

United States Institute of Theatre
Technology. *See* USITT

Unpacking 1-2

Upgrade. *See* Uploading software

Uploading software A-1

USITT 2-2

V

Version number 1-24

Voltage rating. *See* Specifications

Voltage settings 1-10 to 1-14

Voltage, reading 1-24

Z

W

Wheels

- cleaning 3-7 to 3-10
- color, replacing dichroics 3-22
- effects C-7
- rotating litho, removing and installing
3-19 to 3-21
- static litho, replacing lithos 3-22

Wheels, factory configurations

- CL/SV color C-6
- CL/SV rotating litho C-4
- CL/SV static litho C-2
- CX color C-5
- CX rotating litho C-3
- CX static litho C-1
- effects C-7

X

XLR cabling

- constructing 2-6 to 2-7
- ordering 1-7
 - C-clamps
 - ordering 1-7
- pinouts 2-6, 2-7
- terminators 2-7

Xmit LED description 1-27

Y

Yoke

- adjusting 3-26
- installing 1-14 to 1-15