

tourwashTM

575 automated fixture



version 1.1

tourwashTM 575 automated fixture

The information contained in this publication has been carefully prepared and checked. However, no responsibility will be taken for any errors. All rights are reserved and this document cannot be copied, photocopied or reproduced, in part or completely, without prior written consent from Tourwash.

Tourwash reserves the right to make any aesthetic, functional or design modifications to any of its products without prior notice. Tourwash assumes no responsibility for the use or application of the products or circuits described herein.

For technical assistance please contact:
A.C. Lighting Ltd.
Centauri House, Hillbottom Road
High Wycombe, Bucks. HP12 4HQ. UK

Tel: +44 (0)1494 446000 Fax: +44 (0)1494 461024
sales@aclighting.com www.aclighting.com



CONTENTS

1	Features	4
2	Important safety information	5
	2.1 Fire prevention	
	2.2 Prevention of electric shock	
	2.3 Protection against ultraviolet radiation	
	2.4 Safety	
	2.5 Protection against the penetration of solid and liquid matter	
3	Changing the lamp	5
	3.1 Lamp Specification	
	3.2 Changing the lamp	
	3.3 Lamp alignment	
4	Voltage and frequency	6
5	Installation	6
	5.1 Overview	
	5.2 Safety bond	
	5.3 Protection against liquids	
	5.4 Movement	
	5.5 Risk of fire	
	5.6 Air ventilation	
	5.7 Ambient temperature	
6	Mains connection	7
	6.1 Connection	
	6.2 Protection	
7	DMX signal connection	8
	7.1 Overview	
	7.2 Alternative connections	
	7.3 DMX addresses	
	7.4 Changing the DMX address	
8	Menu functions	9
	8.1 Menu Functions	
	8.2 Automatic operation (AUTO)	
	8.3 GAN1/2/3	
	8.4 GANP	
	8.5 Pan & tilt speed (SPEE)	
	8.6 Fan speed (FANS)	
9	Error messages	12
10	Hidden menu	12
11	Opening up the fixture housing	13
12	Periodic maintenance	13
	12.1 Lenses and reflectors	
	12.4 Fans and air ducts	
	12.3 Lamp	
	12.4 Mechanical parts	
	12.5 Electrical components	
	12.6 Fuse replacement	
	Appendix 1: Wiring connections	15
	Appendix 2: DMX protocols	17

tourwashTM 575 automated fixture

1 Features

- 575W discharge lamp
- Turn-on and turn-off of the lamp by DMX or by menu
- Pan/Tilt range of 540°/320°, 16 bit
- 200mm Fresnel lens with motorised zoom (16°-28°)
- Beam shaping
- CMY colour mixing system
- Colour wheel with 8 colours incl. 3200°K and 5600°K
- Dimmer
- Strobe
- Frost
- DMX control and stand-alone mode
- Automatic feedback system
- Convenient ¼ turn fasteners
- Weight: 26kg



Hanging centres: 500mm

tourwashTM 575 automated fixture

2 Important safety information

2.1 Fire prevention

1. Never locate the fixture on any flammable surface.
2. Minimum distance from flammable materials: 0.5 m.
3. Minimum projection distance: 2 m.
4. Replace any blown or damaged fuses only with those of identical value. Refer to the wiring diagram if there is any doubt.
5. Connect the fixture to mains power via a thermal magnetic circuit breaker.

2.2 Prevention of electric shock

1. High voltage is present inside the unit. Isolate the fixture from the mains supply prior to performing any function which involves touching the inside of the unit, including lamp replacement.
2. The technology used in the Tourwash 575 requires the assistance of trained personnel for all servicing. Refer all service work to your authorised Tourwash service centre.
3. A good earth connection is essential for proper functioning of the fixture. Never connect the unit without proper earth connection.
4. The fixture should never be located in a position exposed to moisture or extreme humidity. A steady supply of circulating air is essential.

2.3 Protection against ultraviolet radiation

1. Never turn the lamp on if any of the lenses, filters or the ABS housing is damaged. Their shielding functions will only operate efficiently if they are undamaged.
2. Never look directly into the lamp when it is on.

2.4 Safety

1. The fixture should always be installed with fixings that are capable of supporting the weight of the unit.
2. Always use a secondary safety bond of a suitable drop rating to sustain the weight of the unit in case of the failure of the main fixing point.
3. The external surface of the unit may exceed 150°C. Allow 10 minutes from lamp off before handling.
4. Always replace the lamp if any physical damage is evident.
5. Never install the fixture in an enclosed area lacking sufficient air flow. The ambient temperature should not exceed 35°C.
6. A hot lamp may explode. Allow 10 minutes from lamp off before attempting to replace the lamp.
7. Always wear suitable hand protection when handling the lamp.

2.5 Protection against the penetration of solids & liquids

The fixture is classified as an ordinary appliance and its level of protection against the penetration of solids and liquids is IP 20.

3 Changing the lamp

3.1 Lamp specification

Lamp:	GE CSR 575/2	Osram HSR 575/2	Philips MSR 575/2
Power:	575W	575W	575W
Luminous flux:	49,000 lm	49,000 lm	49,000 lm
Colour temperature:	5600°K	5600°K	5600°K
Lampbase:	GX9.5	GX9.5	GX9.5
Rated life:	1,000 hours	1,000 hours	1,000 hours

tourwashTM 575 automated fixture

3.2 Changing the lamp



Photo 1

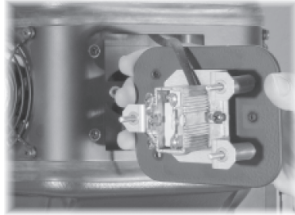

Photo 2

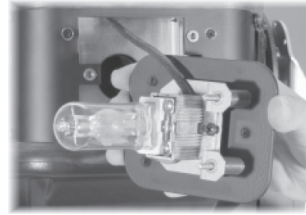

Photo 3



Photo 4

Note: turn power off before opening the fixture

1. Using a crosshead screwdriver, remove the 3 screws (X, Y, Z) located at the rear of the fixture head (photo 1, black screws).
2. Remove the lampholder assembly (photo 2).
3. Insert the lamp (photo 3).
The lamp used is manufactured from quartz glass and should be handled with care. Always adhere to the instructions supplied in the lamp's packaging. Never touch the glass directly but use the tissue provided in the lamp's packaging. The GX 9.5 lamphouse is symmetrical. DO NOT USE UNDUE FORCE ON THE GLASS. In case of difficulty, re-read the instructions and repeat the procedure.
4. Replace the lampholder assembly (photo 4) and replace and tighten the screws (X, Y, Z), which were previously removed (photo 1).

3.3 Lamp alignment

Note: each time a lamp is changed we recommend that the lamp be optically realigned to avoid overheating of components inside the unit (photo 5).



Photo 5

Alignment is carried out using the 3 crosshead screw adjusters A, B and C (silver screws). During this operation you must bring the hot-spot to the centre of the beam and flatten it as much as possible.

4 Voltage and frequency

The fixture can operate at 230V 50 or 60 Hz. Tourwash 575 is factory set to operate at 230V 50Hz.

5 Installation

5.1 Overview

Tourwash 575 may be fixed in any orientation. For floor mounting, the Tourwash 575 is supplied with four rubber mounting feet on the base. For any other orientation the use of the quick fixing mounting bracket (supplied as standard) will be required. Four quarter turn fasteners are located on the base of the fixture to mount the quick fixing bracket. The supporting structure from which the unit is fixed should be capable of bearing the weight of the unit. The structure should also be sufficiently rigid so as not to move or shake whilst the Tourwash 575 moves during its operation.



tourwashTM 575 automated fixture

5.2 Safety bond

We recommend the use of a secondary safety bond to secure the Tourwash 575 to the supporting structure in the event of the failure of the primary fixings. Ensure that the safety bond can withstand the drop weight of the entire unit. You may attach the safety bond to the two holes (A) located on the base of the fixture, as shown in the diagram below.

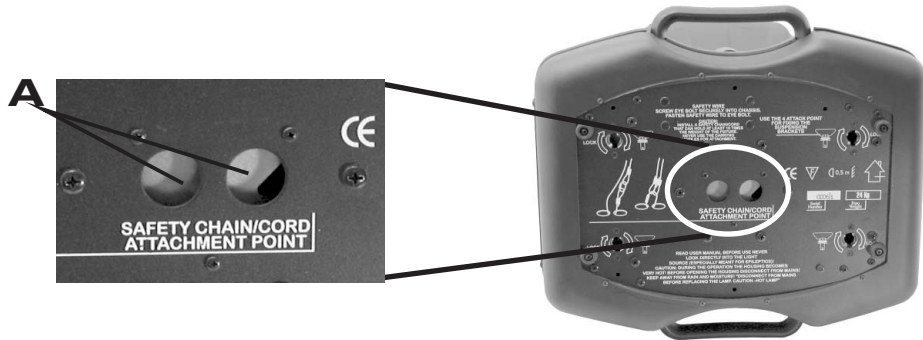

5.3 Protection against liquids

The fixture contains electric and electronic components which should, under no circumstances, come into contact with liquid.

5.4 Movement

The fixture has a maximum movement of 540° pan and 319° tilt. Do not place any obstructions in the path of the fixture's movement.



5.5 Risk of fire

Each fixture produces heat and must be installed in a well-ventilated area. The minimum recommended distance from flammable material is 0.5m. Minimum distance from the object being illuminated is 2m.

5.6 Air ventilation

The fixture features various air inlets and cooling fans located on both the base and head. Under no circumstances should these be blocked or obstructed whilst the fixture is in operation. Doing so could cause the fixture to seriously overheat thereby compromising its reliable operation.

5.7 Ambient temperature

The fixture should never be installed in places that lack a constant flow of air. The ambient temperature should NOT exceed 35°C.

6 Mains connection

6.1 Connection

Tourwash 575 operates at 230V 50 or 60Hz. Prior to connecting the unit to your mains supply, please ensure that the settings correctly match the mains supply available and the plug fitted is suitably rated at 8A at 230V. The replaceable fuse is a T6.3A L250V 20mm.



230V at 50 or 60Hz

tourwashTM 575 automated fixture

6.2 Protection

The use of a thermal magnetic circuit breaker is recommended for each Tourwash 575. A good earth connection is essential for the correct operation of the fixture.

7 DMX connection

7.1 Overview

The fixture operates using a DMX 512 (1990) data signal. Only use twin screened DMX cable similar to Tourflex Datasafe for reliable operation.

Connect the control cable to the DMX In connection and daisy-chain it to the next fixture by connecting the DMX Out connector on the first fixture to the DMX In connector on the second, and so on.

Note: If the display showing the DMX address flashes, then one of the following errors has occurred:

- DMX signal not present
- DMX address not valid
- DMX reception problem

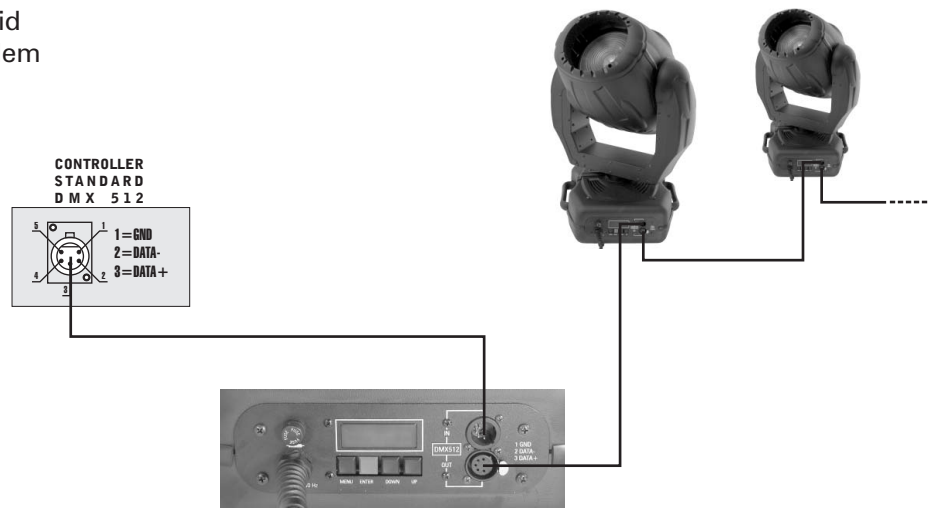

7.2 Alternative connections

The Tourwash 575 has both 3 pin and 5 pin XLR connections fitted. The standard configuration is with XLR 5 connectors. To convert to an XLR 3 configuration proceed as follows:

1. Remove the external cover (photo 1).
2. Unscrew the external fixings for the connector panel (photo 2).
3. Rotate the circuit board by 180° (photo 3).
4. Refit the circuit board with the XLR 3 connectors in position and replace the cover.



Photo 1



Photo 2

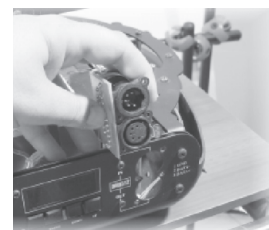

Photo 3

7.3 DMX addresses

Tourwash 575 can be used in four different modes: 9 (8 bit), 9 (16 bit), 13 (8 bit) or 15 (16 bit) channels. For instructions on selecting the DMX control mode, please refer to section 8.1. See Appendix 2 for the various protocols detailing channel assignments.

7.4 Changing the DMX address

1. Press the UP-DOWN buttons until you reach the required DMX address. The numbers on the display will start to flash (but the new DMX address hasn't yet been set).
2. Press and hold ENTER for two seconds to confirm your selection. The numbers on the display will stop flashing and the fixture is now addressed at the number shown.

Note: if you press the UP-DOWN keys together the display changes faster.

tourwash™ 575 automated fixture

8 Menu functions

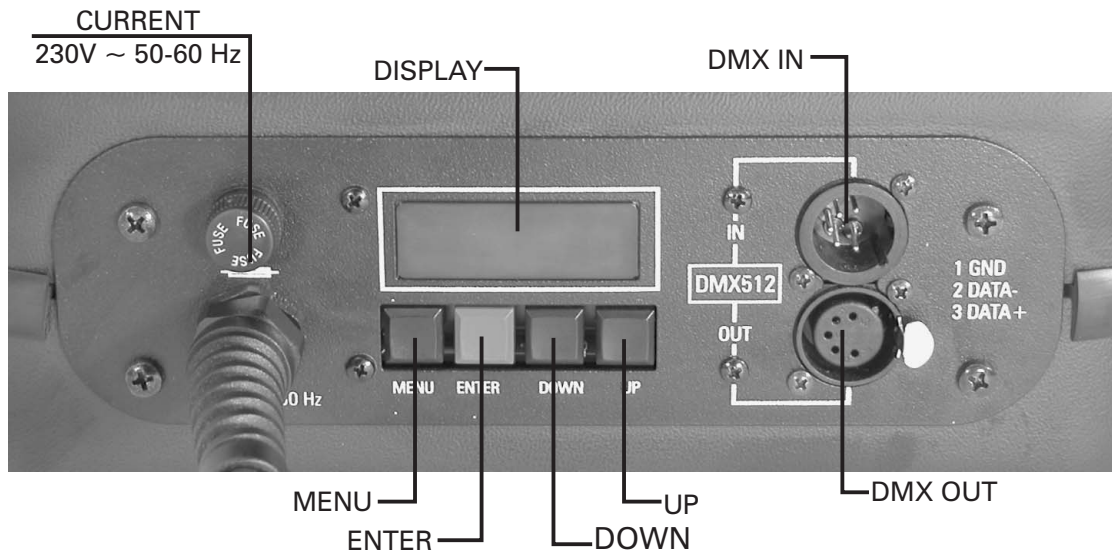



























8.1 Menu Functions

The Tourwash 575 display panel shows all the menu functions available. By navigating the menu, it is possible to select the operation mode and test functions.

To enter the menu, press and hold the MENU button for two seconds. To adjust settings use the UP and DOWN buttons. To confirm a selection press ENTER. To exit press MENU.

Note: the symbol  shows which button has to be pushed to obtain the selection required.

 	ADD 1	 	Pd ir	 	CU	CLOCKWISE		
		PAN DIRECTION To invert selection between clockwise and counterclockwise pan direction.			CCU	COUNTERCLOCKWISE		
 	td ir	 	CU	CLOCKWISE				
		TILT DIRECTION To invert selection between clockwise and counterclockwise tilt direction.			CCU	COUNTERCLOCKWISE		
	d ISP	 	POS 1	 	AA	BB		
		DISPLAY Position - Inverts the display text. Standby - Sets the display to blackout unless in use or showing error.			Stby	 	ON	OFF
 	node	 	15.16	15 CHANNEL Pan/Tilt 16 bit				
		DMX MODE To select DMX control mode			13.8	13 CHANNEL Pan/Tilt 8 bit		
					9.16	9 CHANNEL Pan/Tilt 16 bit		
					9.8	9 CHANNEL Pan/Tilt 8 bit		

tourwash™ 575 automated fixture

MENU Up-Down TEST ENTER TEST

TEST
Complete test sequence one function at a time.

MENU Up-Down AUTO ENTER SUR-E ENTER Up-Down GAN1
Up-Down GAN2 ENTER SPEE
Up-Down GAN3 2000
Up-Down GANP ENTER SPEE
Up-Down ESC

AUTOMATIC
Stand alone programs with speed adjustment.

MENU Up-Down RESE ENTER RESE

RESET
To activate complete reset.

MENU Up-Down DFSE ENTER SUR-E ENTER

DEFAULT SETTINGS
To restore factory default settings.

MENU Up-Down SOFT ENTER 14.12
SOFTWARE Pcb 8 motors . Pcb PAN&TILT
To display software version.

MENU Up-Down FAN5 ENTER Up-Down 1 ENTER
Up-Down 12

FAN SPEED
To adjust the cooling fan speed.

MENU Up-Down SPEE ENTER Up-Down 1 ENTER
Up-Down 4 ENTER

SPEED
To change the maximum speed of pan and tilt motors.

MENU Up-Down LAMP ENTER dNH ENTER ON / OFF VIA DMX
Up-Down on ENTER FORCED ON (setting default)
Up-Down off ENTER FORCED OFF

LAMP
ON/OFF lamp

MENU Up-Down REC ENTER Up-Down 1SCH ENTER r.017
Up-Down 9CH

RECORD
Record mode for use with GANP.

MENU Up-Down SLAV ENTER SUR-E ENTER Up-Down SLU
ESC

SLAVE
To set as slave when used with master in GANP.

MENU Up-Down TIME ENTER Up-Down LAMP ENTER
Up-Down Unit ENTER
Up-Down rESL ENTER

TIME
Display of lamp hours (resettable) and total operation hours (not resettable).

tourwashTM 575 automated fixture

8.2 Automatic operation (auto)

Tourwash 575 can work in synchronised stand alone mode without a control desk. First of all connect the fixtures with DMX cable (see picture below).

MASTER

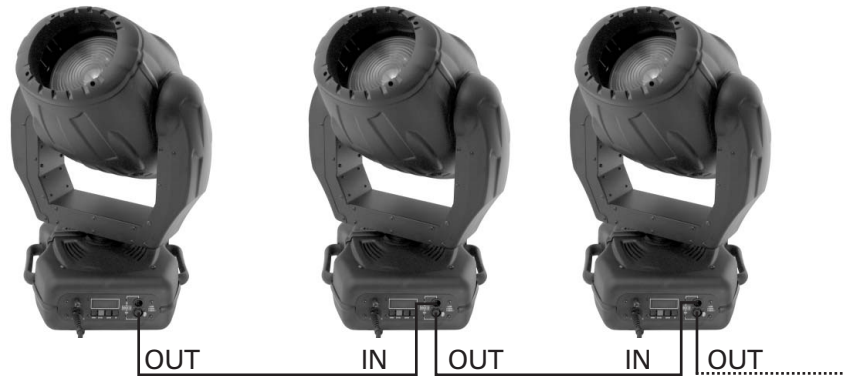

8.3 GAN1/2/3

GAN1/2/3 are factory defined programs with adjustable speed and focus. The master fixture should be placed in AUTO mode, the other fixtures should be set to 15 channel DMX Mode and the DMX address should be set at 001. Once a program is chosen press ENTER, choose between speed (SPEE) and zoom (ZooN), press ENTER to adjust. All fixtures will now replicate the master.

8.4 GANP

GANP is a user definable program of 16 linked scenes which require a control desk to record. Playback, however, is stand alone.

RECORD

Enter record (REC) and set all fixtures to the same DMX channel mode (15 (16 bit) or 9 (16 bit)). When in record mode 3 additional DMX channels are required per fixture to enable the GANP internal scenes to be selected and recorded.

Set individual DMX addresses for each fixture remembering to add 3 additional channels. Any Tourspot or Tourwash model can be used in this mode. Adjust fixture parameters with the console and use the additional 3 channels to program the internal scenes of the fixtures.

Additional channel 1	Scene	selects last scene or scene to be recorded
Additional channel 2	Control	1-19=scene playback, 20-235=scene channel in record mode, 236-255=scene channel sets last scene in sequence
Additional channel 3	Record	0=off, 255=record

PLAYBACK

To playback the recorded scenes, the master fixture should be placed in GANP and the other fixtures should be set to slave (SLAV). The speed of playback can be adjusted by pressing ENTER on the master fixture.

8.5 Pan & tilt speed (SPEE)

You can adjust the maximum speed of the pan and tilt movement between 1 and 4, default is 2.

8.6 Fan speed (FANS)(default: 12)

You can adjust the maximum speed of the cooling fans to reduce noise between 1 and 12, default is 12. Adjustment will affect efficient cooling and may result in the thermal cutout being activated. It is important that the ambient temperature is less than 35°C.

tourwashTM 575 automated fixture

9 Error messages

	—————	Error encoder pan
	—————	Error encoder tilt
	—————	Error adress dmx
	—————	Error loading eprom data
	—————	Error colour sensor circuit/zoom 1
	—————	Error colour sensor circuit/zoom 2
	—————	Error positioning of colour wheel
	—————	Error positioning of beam shape effects
	—————	Error positioning of zoom
	—————	Error alignment sensors of zoom lens
	—————	Error input in auto mode
	—————	Error internal communication
	—————	Error synchronized frequency measure (Synchronism for lamp ON)

10 Hidden menu (for technical personnel only)

To access the hidden menu connect the fixture to DMX and access the reset (rESE) menu from the display. Whilst resetting press MENU and ENTER buttons at the same time.

	Electronic calibration of the motors
	Reset EPROM NOTE: by pressing this button you must re-calibrate all functions
	Exit from hidden menu

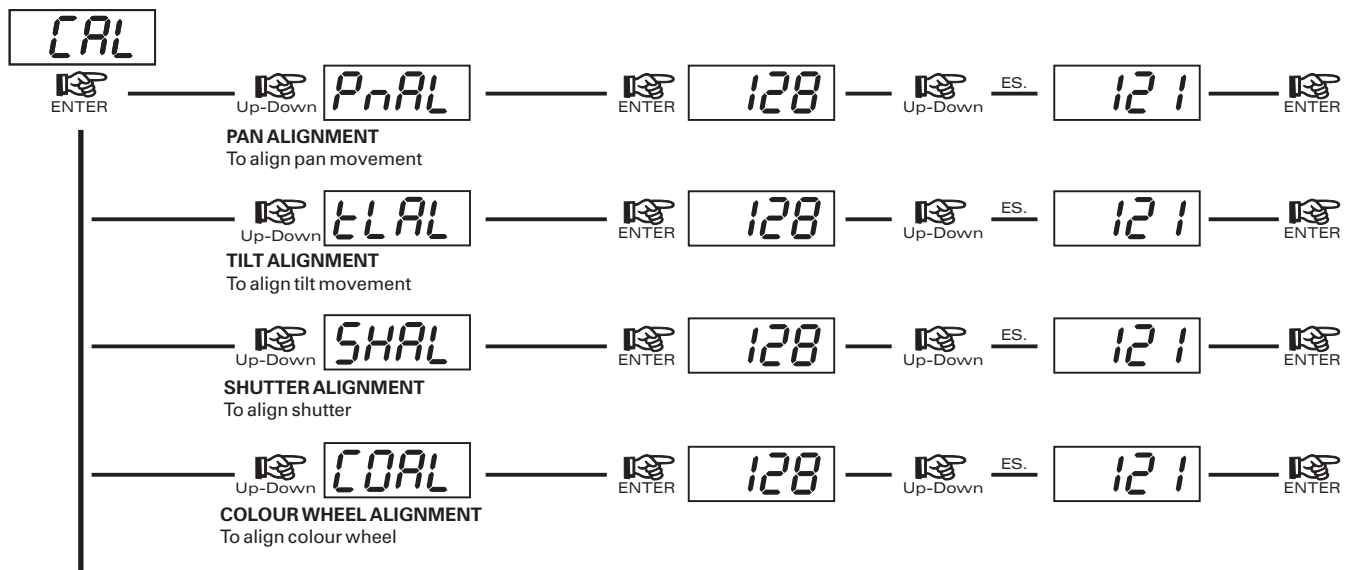

tourwash™ 575 automated fixture

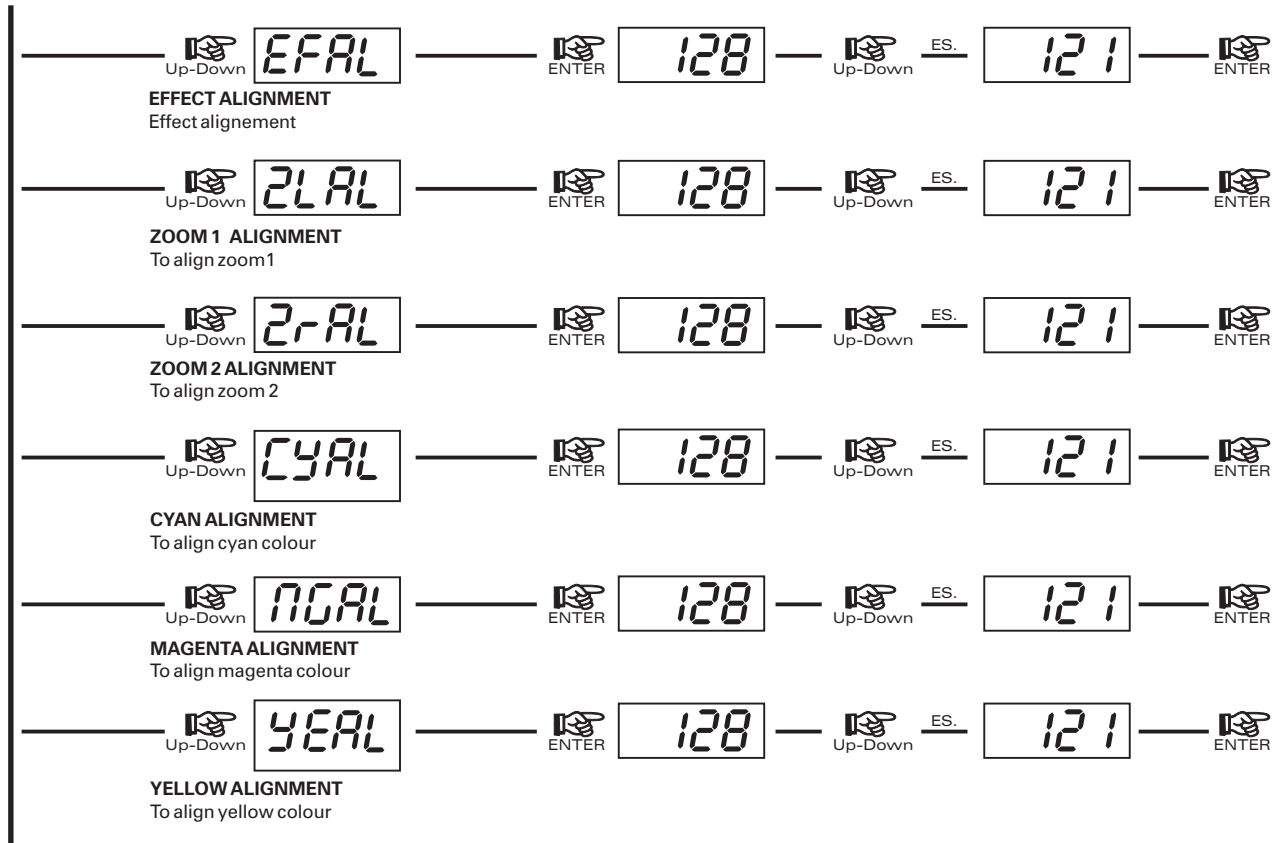

11 Opening up the fixture housing

It is possible to inspect the inside of the fixture by removing the cover as indicated below.

Note: isolate mains power prior to removing the covers.

1. Loosen (do not remove) the four screws which secure the front nose moulding (photo 1)
2. Remove the four side cover retaining screws (two each side) (photo 2).
3. Lift the covers to remove (photo 3).



Photo 1



Photo 2



Photo 3

12 Periodic maintenance

Note: Disconnect mains power prior to removing the fixture housing.

12.1 Lenses and reflectors

Even a fine layer of dust can reduce the light output substantially. Regularly clean the reflector and all lenses using a soft cotton cloth, dampened with a specialist lens cleaning solution.

12.2 Fans and air ducts

In normal conditions the fans and air ducts must be cleaned approximately every 6 weeks. This can be achieved with a paint brush and domestic vacuum cleaner or compressed air. If necessary, clean the fans and air ducts more frequently.

12.3 Lamp

tourwash[™] 575 automated fixture

The lamp should be replaced if there is any visible damage. This will help to avoid the danger of the lamp exploding.

12.4 Mechanical parts

Periodically check all mechanical parts, gears, guides, belts etc. for wear and tear, replacing them if necessary. Periodically check the lubrication of all components, particularly the parts subject to high temperatures. If necessary, lubricate with suitable lubricant, available from your Tourwash distributor. Check the tension of all belts and adjust if necessary.

12.5 Electrical components

Check all electrical components for correct earthing and secure attachment of all connectors, refastening if necessary.

12.6 Fuse replacement

The fuse which protects the lamp and electronics, is mounted in the base of the Tourwash 575. Test the condition of the fuse using a multimeter, replacing it with one of equivalent type if necessary.

tourwash™ 575 automated fixture

Appendix 1: Wiring connections

MOTOR ACTUATOR CARD

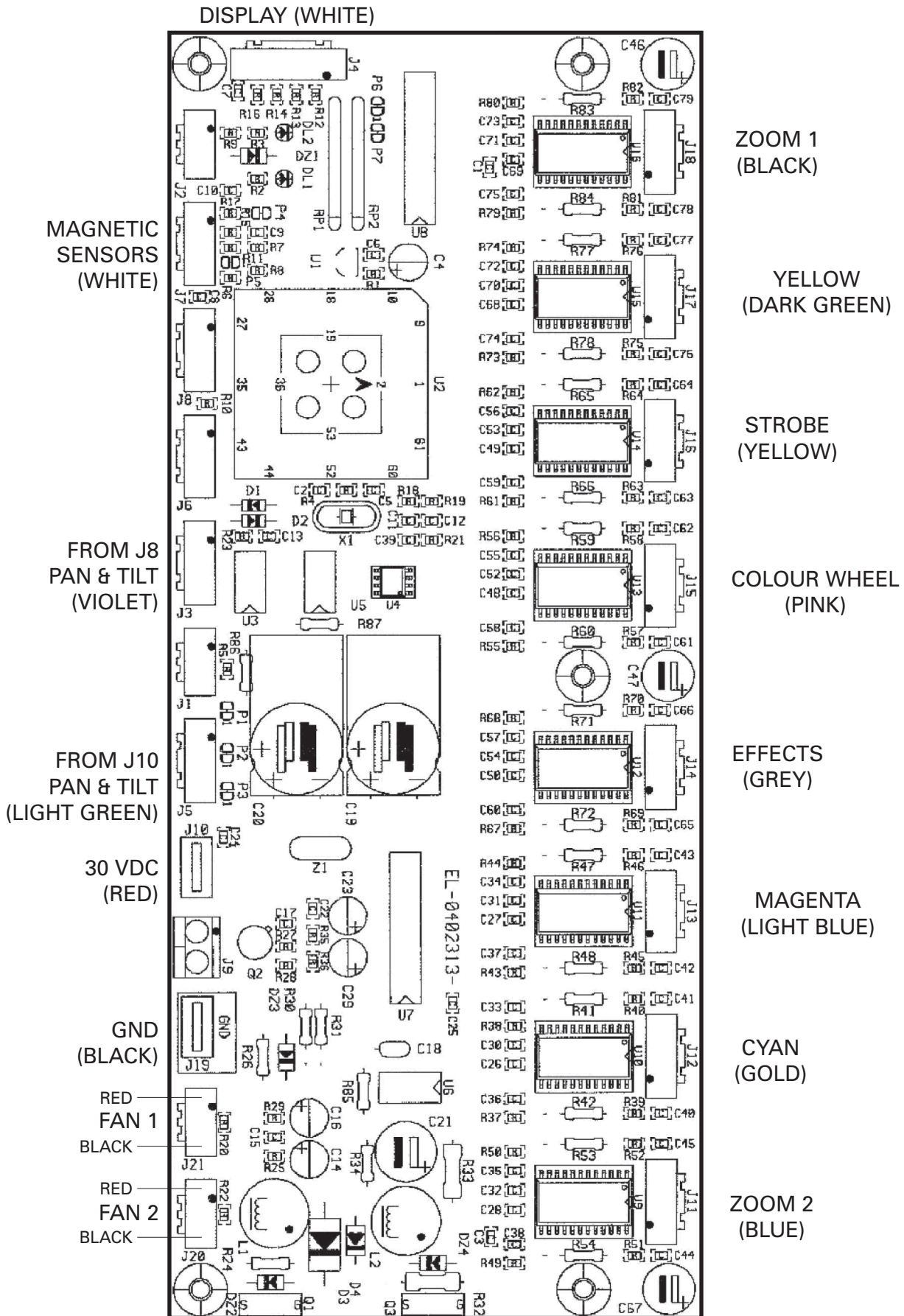

tourwash™ 575 automated fixture

Display card

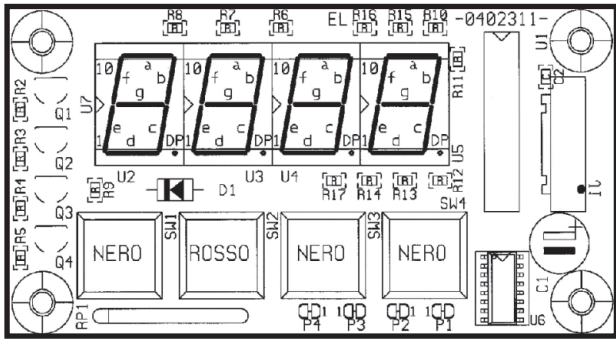

FROM J4
8 MOTOR

ON / OFF Lamp card

IN LAMP
OUT LAMP

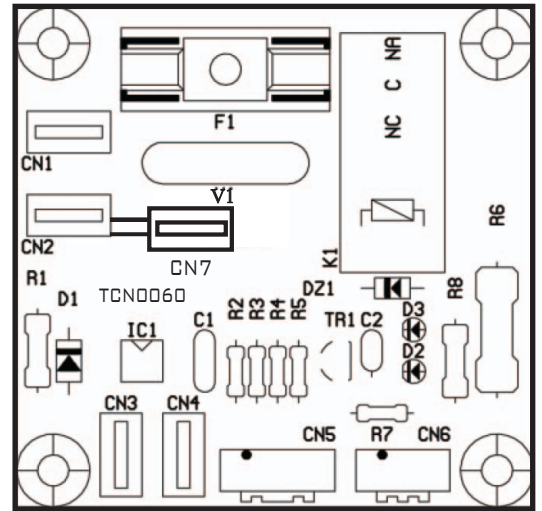

24V~

FROM J16
PAN & TILT
CARD
FROM J7
PAN & TILT
CARD

If the PCB card doesn't work, move the cable "IN LAMP" from Cn1 to Cn7

To delete **Snr** error from display, in menu **LAMP** select **off**

Pan & tilt card

ENCODER PAN
(RED)

ENCODER TILT
(ORANGE)

DATA 1
(VIOLET)
DATA 2
(LIGHT GREEN)
MOTOR TILT
(BROWN)

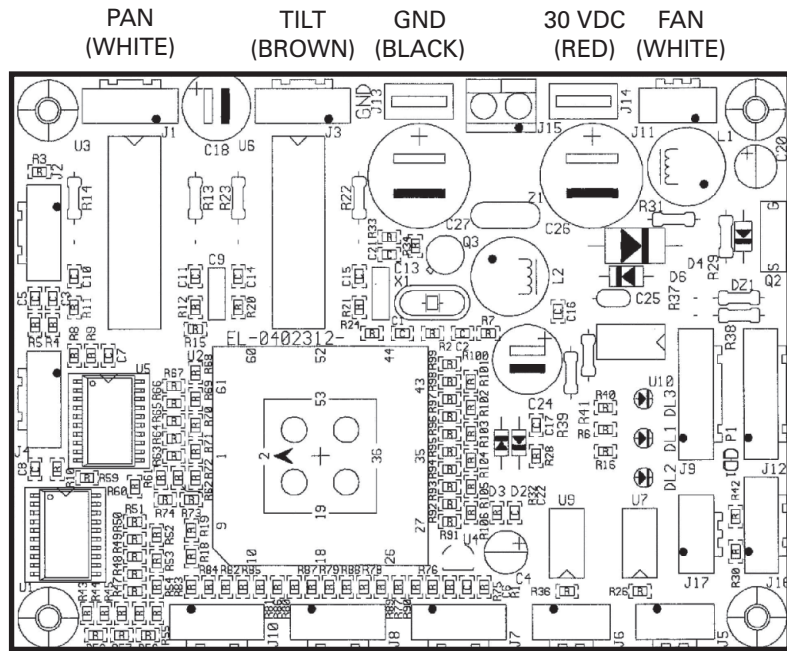

J17 FROM Cn6
on/off lamp card
J16 FROM Cn5
on/off lamp card

FROM J5
8 MOTOR
(LIGHT GREEN)
FROM J3
8 MOTOR
(VIOLET)

DMX INPUT
(WHITE)

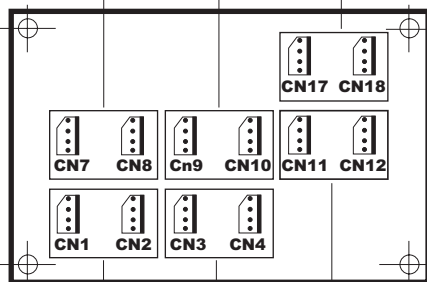

DISPLAY 1
DISPLAY 2
ENCODER TILT
(ORANGE)

Conector relay card

tourwash™ 575 automated fixture



DMX MODE

To select DMX control mode

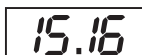

15 CHANNEL Pan/Tilt 16 bit



13 CHANNEL Pan/Tilt 8 bit



9 CHANNEL Pan/Tilt 16 bit



9 CHANNEL Pan/Tilt 8 bit

Appendix 2: DMX Protocol

15 Channel mode (16 bit) (15.16)

DMX CHANNEL	1	PARAMETER:	PAN Coarse
DMX CHANNEL	2	PARAMETER:	PAN Fine
DMX CHANNEL	3	PARAMETER:	TILT Coarse
DMX CHANNEL	4	PARAMETER:	TILT Fine
DMX CHANNEL	5	PARAMETER:	MOVEMENT SPEED
DMX RANGE VALUE	MID POINT DMX VALUE	MOVE RANGE (DEGREES)	FUNCTION
0 – 10			Standard
11 – 25			Fast movement
26 – 127			Vector mode from fast to slow
128 – 247			Variable time reaction to DMX signal (fast to slow)
248 – 255			Slow reaction time to DMX signal
DMX CHANNEL	6	PARAMETER:	DIMMER
DMX RANGE VALUE	MID POINT DMX VALUE	MOVE RANGE (DEGREES)	FUNCTION
0 – 8			Black-out
9 – 255			PROPORTIONAL DIMMER
DMX CHANNEL	7	PARAMETER:	SHUTTER
DMX RANGE VALUE	MID POINT DMX VALUE	MOVE RANGE (DEGREES)	FUNCTION
0 – 9			Black out
10 – 23			Strobe random speed
24 – 37			Strobe Speed 1 min
38 – 51			Strobe Speed 2
52 – 65			Strobe Speed 3
66 – 79			Strobe Speed 4
80 – 93			Strobe Speed 5
94 – 107			Strobe Speed 6 MAX
108 – 121			Pulse open speed 1 min
122 – 135			Pulse open speed 2
136 – 149			Pulse open speed 3
150 – 163			Pulse open speed 4 MAX
164 – 177			Pulse closed speed 1 min
178 – 191			Pulse closed speed 2
192 – 205			Pulse closed speed 3
206 – 219			Pulse closed speed 4 MAX
220 – 227			COLOUR/MACRO in BLACKOUT
228 – 233			PAN & TILT in BLACKOUT
234 – 255			Open

tourwashTM 575 automated fixture

DMX CHANNEL	8	PARAMETER:	COLOUR
DMX RANGE VALUE	MID POINT DMX VALUE	MOVE RANGE (DEGREES)	FUNCTION
0 – 128			PROPORTIONAL COLOUR 0 - 360°
129 – 143			WHITE
144 – 147			COLOUR1 - CTB
148 – 151			COLOUR2 - CTO
152 – 155			COLOUR3 - UV
156 – 159			Bicolour 3/4
160 – 163			Colour 4 - PRIMARY GREEN
164 – 167			Bicolour 4/5
168 – 171			Colour 5 - ORANGE
172 – 175			Bicolour 5/6
176 – 179			Colour 6 - DEEP MAGENTA
180 – 183			Bicolour 6/7
184 – 187			Colour 7 - DEEP RED
188 – 191			Bicolour 7/8
192 – 195			Colour 8 - DEEP BLUE
196 – 200			Bicolour 8/WHITE
201 – 202			RIGHT ROTATION speed 9 MAX
203 – 205			RIGHT ROTATION speed 8
206 – 208			RIGHT ROTATION speed 7
209 – 211			RIGHT ROTATION speed 6
212 – 214			RIGHT ROTATION speed 5
215 – 217			RIGHT ROTATION speed 4
218 – 220			RIGHT ROTATION speed 3
221 – 223			RIGHT ROTATION speed 2
224 – 226			RIGHT ROTATION speed 1 min
227 – 229			STOP
230 – 232			LEFT ROTATION speed 1 min
233 – 235			LEFT ROTATION speed 2
236 – 238			LEFT ROTATION speed 3
239 – 241			LEFT ROTATION speed 4
242 – 244			LEFT ROTATION speed 5
245 – 247			LEFT ROTATION speed 6
248 – 250			LEFT ROTATION speed 7
251 – 253			LEFT ROTATION speed 8
254 – 255			LEFT ROTATION speed 9 MAX
DMX CHANNEL	9	PARAMETER:	CYAN
DMX RANGE VALUE	MID POINT DMX VALUE	MOVE RANGE (DEGREES)	FUNCTION
0 – 255			PROPORTIONAL COLOUR
DMX CHANNEL	10	PARAMETER:	MAGENTA
DMX RANGE VALUE	MID POINT DMX VALUE	MOVE RANGE (DEGREES)	FUNCTION
0 – 255			PROPORTIONAL COLOUR

tourwashTM 575 automated fixture

DMX CHANNEL	11	PARAMETER:	YELLOW
DMX RANGE VALUE	MID POINT DMX VALUE	MOVE RANGE (DEGREES)	FUNCTION
0 – 255			PROPORTIONAL COLOUR
DMX CHANNEL	12	PARAMETER:	SPEED CMY/DIMMER
DMX RANGE VALUE	MID POINT DMX VALUE	MOVE RANGE (DEGREES)	FUNCTION
0 – 7			NO FUNCTION
8 – 255			Modo speed da MAX a min
DMX CHANNEL	13	PARAMETER:	BEAM SHAPE / FROST
DMX RANGE VALUE	MID POINT DMX VALUE	MOVE RANGE (DEGREES)	FUNCTION
0 – 19			NO EFFECT
20 – 39			FROST
40 – 255			BEAM SHAPE
DMX CHANNEL	14	PARAMETER:	ZOOM
DMX RANGE VALUE	MID POINT	MOVE RANGE	FUNCTION
0 – 255			PROPORTIONAL
DMX CHANNEL	15	PARAMETER:	RESET
DMX RANGE VALUE	MID POINT DMX VALUE	MOVE RANGE (DEGREES)	FUNCTION
0 – 29			NO EFFECT
30 – 85			Lamp OFF
86 – 170			internal motor reset
171 - 235			total reset
236-255			Lamp ON

tourwashTM 575 automated fixture

13 Channel mode (8 bit) (13.8)			
DMX CHANNEL	1	PARAMETER:	PAN
DMX CHANNEL	2	PARAMETER:	TILT
DMX CHANNEL	3	PARAMETER:	MOVEMENT SPEED
DMX RANGE VALUE	MID POINT DMX VALUE	MOVE RANGE (DEGREES)	FUNCTION
0 – 10			Standard
11 – 25			Fast movement
26 – 127			Vector mode from fast to slow
128 – 247			Variable time reaction to DMX signal (fast to slow)
248 – 255			Slow reaction time to DMX signal
DMX CHANNEL	4	PARAMETER:	DIMMER
DMX RANGE VALUE	MID POINT DMX VALUE	MOVE RANGE (DEGREES)	FUNCTION
0 – 8			Black-out
9 – 255			PROPORTIONAL DIMMER
DMX CHANNEL	5	PARAMETER:	SHUTTER
DMX RANGE VALUE	MID POINT DMX VALUE	MOVE RANGE (DEGREES)	FUNCTION
0 – 9			Black out
10 – 23			Strobe random speed
24 – 37			Strobe Speed 1 min
38 – 51			Strobe Speed 2
52 – 65			Strobe Speed 3
66 – 79			Strobe Speed 4
80 – 93			Strobe Speed 5
94 – 107			Strobe Speed 6 MAX
108 – 121			Pulse open speed 1 min
122 – 135			Pulse open speed 2
136 – 149			Pulse open speed 3
150 – 163			Pulse open speed 4 MAX
164 – 177			Pulse closed speed 1 min
178 – 191			Pulse closed speed 2
192 – 205			Pulse closed speed 3
206 – 219			Pulse closed speed 4 MAX
220 – 227			COLOUR/MACRO in BLACKOUT
228 – 233			PAN & TILT in BLACKOUT
234 – 255			Open
DMX CHANNEL	6	PARAMETER:	COLOUR
DMX RANGE VALUE	MID POINT DMX VALUE	MOVE RANGE (DEGREES)	FUNCTION
0 – 128			PROPORTIONAL COLOUR 0 - 360°
129 – 143			WHITE
144 – 147			COLOUR1 - CTB
148 – 151			COLOUR2 - CTO
152 – 155			COLOUR3 - UV
156 – 159			Bicolour 3/4
160 – 163			Colour 4 - PRIMARY GREEN
164 – 167			Bicolour 4/5

tourwashTM 575 automated fixture

168 – 171			Colour 5 - ORANGE
172 – 175			Bicolour 5/6
176 – 179			Colour 6 - DEEP MAGENTA
180 – 183			Bicolour 6/7
184 – 187			Colour 7 - DEEP RED
188 – 191			Bicolour 7/8
192 – 195			Colour 8 - DEEP BLUE
196 – 200			Bicolour 8/WHITE
201 – 202			RIGHT ROTATION speed 9 MAX
203 – 205			RIGHT ROTATION speed 8
206 – 208			RIGHT ROTATION speed 7
209 – 211			RIGHT ROTATION speed 6
212 – 214			RIGHT ROTATION speed 5
215 – 217			RIGHT ROTATION speed 4
218 – 220			RIGHT ROTATION speed 3
221 – 223			RIGHT ROTATION speed 2
224 – 226			RIGHT ROTATION speed 1 min
227 – 229			STOP
230 – 232			LEFT ROTATION speed 1 min
233 – 235			LEFT ROTATION speed 2
236 – 238			LEFT ROTATION speed 3
239 – 241			LEFT ROTATION speed 4
242 – 244			LEFT ROTATION speed 5
245 – 247			LEFT ROTATION speed 6
248 – 250			LEFT ROTATION speed 7
251 – 253			LEFT ROTATION speed 8
254 – 255			LEFT ROTATION speed 9 MAX
DMX CHANNEL	7	PARAMETER:	CYAN
DMX RANGE VALUE	MID POINT DMX VALUE	MOVE RANGE (DEGREES)	FUNCTION
0 – 255			PROPORTIONAL COLOUR
DMX CHANNEL	8	PARAMETER:	MAGENTA
DMX RANGE VALUE	MID POINT DMX VALUE	MOVE RANGE (DEGREES)	FUNCTION
0 – 255			PROPORTIONAL COLOUR
DMX CHANNEL	9	PARAMETER:	YELLOW
DMX RANGE VALUE	MID POINT DMX VALUE	MOVE RANGE (DEGREES)	FUNCTION
0 – 255			PROPORTIONAL COLOUR
DMX CHANNEL	10	PARAMETER:	SPEED CMY / DIMMER
DMX RANGE VALUE	MID POINT DMX VALUE	MOVE RANGE (DEGREES)	FUNCTION
0 – 7			NO FUNCTION
8 – 255			Mode speed from MAX to min

tourwashTM 575 automated fixture

DMX CHANNEL	11	PARAMETER:	BEAM SHAPE / FROST
DMX RANGE VALUE	MID POINT DMX VALUE	MOVE RANGE (DEGREES)	FUNCTION
0 – 19			NO EFFECT
20 – 39			FROST
40 – 255			BEAM SHAPE
DMX CHANNEL	12	PARAMETER:	ZOOM
DMX RANGE VALUE	MID POINT DMX VALUE	MOVE RANGE (DEGREES)	FUNCTION
0 – 255			PROPORTIONAL
DMX CHANNEL	13	PARAMETER:	RESET
DMX RANGE VALUE	MID POINT DMX VALUE	MOVE RANGE (DEGREES)	FUNCTION
0 – 29			NO EFFECT
30 – 85			lamp OFF
86 – 170			internal motor reset
171 – 235			total reset
236 – 255			lamp ON

tourwashTM 575 automated fixture

9 Channel mode (16 bit) (9.16)			
DMX CHANNEL	1	PARAMETER:	PAN Coarse
DMX CHANNEL	2	PARAMETER:	PAN Fine
DMX CHANNEL	3	PARAMETER:	TILT Coarse
DMX CHANNEL	4	PARAMETER:	TILT Fine
DMX CHANNEL	5	PARAMETER:	DIMMER / SHUTTER
DMX RANGE VALUE	MID POINT DMX VALUE	MOVE RANGE (DEGREES)	FUNCTION
0 – 9			Black out
10 – 85			Dimmer
86 – 95			Strobe random speed
96 – 105			Strobe Speed 1 min
106 – 115			Strobe Speed 2
116 – 125			Strobe Speed 3
126 – 135			Strobe Speed 4
136 – 145			Strobe Speed 5
146 – 155			Strobe Speed 6 MAX
156 – 165			Pulse open speed 1 min
166 – 175			Pulse open speed 2
176 – 185			Pulse open speed 3
186 – 195			Pulse open speed 4 MAX
196 – 205			Pulse closed speed 1 min
206 – 215			Pulse closed speed 2
216 – 225			Pulse closed speed 3
226 – 235			Pulse closed speed 4 MAX
236 – 245			COLOUR//PAN/TILT/MACRO in BLACKOUT
246 – 255			Open
DMX CHANNEL	6	PARAMETER:	CYM COLOUR MIXING
DMX RANGE VALUE	MID POINT DMX VALUE	MOVE RANGE (DEGREES)	FUNCTION
0 – 35			WHITE
36 – 71			CYAN
72 – 107			VIOLET
108 – 143			MAGENTA
144 – 179			ORANGE
180 – 215			YELLOW
216 – 255			GREEN
DMX CHANNEL	7	PARAMETER:	COLOUR
DMX RANGE VALUE	MID POINT DMX VALUE	MOVE RANGE (DEGREES)	FUNCTION
0 – 128			PROPORTIONAL COLOUR 0 - 360°
129 – 143			WHITE
144 – 147			COLOUR1 - CTB
148 – 151			COLOUR2 - CTO
152 – 155			COLOUR3 - UV
156 – 159			Bicolour 3/4
160 – 163			Colour 4 - PRIMARY GREEN
164 – 167			Bicolour 4/5
168 – 171			Colour 5 - ORANGE
172 – 175			Bicolour 5/6
176 – 179			Colour 6 - DEEP MAGENTA

tourwash™ 575 automated fixture

180 – 183			Bicolour 6/7
184 – 187			Colour 7 - DEEP RED
188 – 191			Bicolour 7/8
192 – 195			Colour 8 - DEEP BLUE
196 – 200			Bicolour 8/WHITE
201 – 202			RIGHT ROTATION speed 9 MAX
203 – 205			RIGHT ROTATION speed 8
206 – 208			RIGHT ROTATION speed 7
209 – 211			RIGHT ROTATION speed 6
212 – 214			RIGHT ROTATION speed 5
215 – 217			RIGHT ROTATION speed 4
218 – 220			RIGHT ROTATION speed 3
221 – 223			RIGHT ROTATION speed 2
224 – 226			RIGHT ROTATION speed 1 min
227 – 229			STOP
230 – 232			LEFT ROTATION speed 1 min
233 – 235			LEFT ROTATION speed 2
236 – 238			LEFT ROTATION speed 3
239 – 241			LEFT ROTATION speed 4
242 – 244			LEFT ROTATION speed 5
245 – 247			LEFT ROTATION speed 6
248 – 250			LEFT ROTATION speed 7
251 – 253			LEFT ROTATION speed 8
254 – 255			LEFT ROTATION speed 9 MAX
DMX CHANNEL	8	PARAMETER:	BEAM SHAPE / FROST
DMX RANGE VALUE	MID POINT DMX VALUE	MOVE RANGE (DEGREES)	FUNCTION
0 – 19			NO EFFECT
20 – 39			FROST
40 – 255			BEAM SHAPE
DMX CHANNEL	9	PARAMETER:	ZOOM
DMX RANGE VALUE	MID POINT DMX VALUE	MOVE RANGE (DEGREES)	FUNCTION
0 – 255			PROPORTIONAL

tourwashTM 575 automated fixture

9 Channel mode (8 bit) (9.8)			
DMX CHANNEL	1	PARAMETER:	PAN
DMX CHANNEL	2	PARAMETER:	TILT
DMX CHANNEL	3	PARAMETER:	DIMMER / SHUTTER
DMX RANGE VALUE	MID POINT DMX VALUE	MOVE RANGE (DEGREES)	FUNCTION
0 – 9			Black out
10 – 85			Dimmer
86 – 95			Strobe random speed
96 – 105			Strobe Speed 1 min
106 – 115			Strobe Speed 2
116 – 125			Strobe Speed 3
126 – 135			Strobe Speed 4
136 – 145			Strobe Speed 5
146 – 155			Strobe Speed 6 MAX
156 – 165			Pulse open speed 1 min
166 – 175			Pulse open speed 2
176 – 185			Pulse open speed 3
186 – 195			Pulse open speed 4 MAX
196 – 205			Pulse closed speed 1 min
206 – 215			Pulse closed speed 2
216 – 225			Pulse closed speed 3
226 – 235			Pulse closed speed 4 MAX
236 – 245			COLOUR/PAN/TILT/MACRO in BLACKOUT
246 – 255			Open
DMX CHANNEL	4	PARAMETER:	CYAN
DMX RANGE VALUE	MID POINT DMX VALUE	MOVE RANGE (DEGREES)	FUNCTION
0 – 255			PROPORTIONAL COLOUR
DMX CHANNEL	5	PARAMETER:	MAGENTA
DMX RANGE VALUE	MID POINT DMX VALUE	MOVE RANGE (DEGREES)	FUNCTION
0 – 255			PROPORTIONAL COLOUR
DMX CHANNEL	6	PARAMETER:	YELLOW
DMX RANGE VALUE	MID POINT DMX VALUE	MOVE RANGE (DEGREES)	FUNCTION
0 – 255			PROPORTIONAL COLOUR
DMX CHANNEL	7	PARAMETER:	COLOUR
DMX RANGE VALUE	MID POINT DMX VALUE	MOVE RANGE (DEGREES)	FUNCTION
0 – 128			PROPORTIONAL COLOUR 0 - 360°
129 – 143			WHITE
144 – 147			COLOUR1 - CTB
148 – 151			COLOUR2 - CTO
152 – 155			COLOUR3 - UV
156 – 159			Bicolour 3/4
160 – 163			Colour 4 - PRIMARY GREEN
164 – 167			Bicolour 4/5

tourwashTM 575 automated fixture

168 – 171			Colour 5 - ORANGE
172 – 175			Bicolour 5/6
176 – 179			Colour 6 - DEEP MAGENTA
180 – 183			Bicolour 6/7
184 – 187			Colour 7 - DEEP RED
188 – 191			Bicolour 7/8
192 – 195			Colour 8 - DEEP BLUE
196 – 200			Bicolour 8/WHITE
201 – 202			RIGHT ROTATION speed 9 MAX
203 – 205			RIGHT ROTATION speed 8
206 – 208			RIGHT ROTATION speed 7
209 – 211			RIGHT ROTATION speed 6
212 – 214			RIGHT ROTATION speed 5
215 – 217			RIGHT ROTATION speed 4
218 – 220			RIGHT ROTATION speed 3
221 – 223			RIGHT ROTATION speed 2
224 – 226			RIGHT ROTATION speed 1 min
227 – 229			STOP
230 – 232			LEFT ROTATION speed 1 min
233 – 235			LEFT ROTATION speed 2
236 – 238			LEFT ROTATION speed 3
239 – 241			LEFT ROTATION speed 4
242 – 244			LEFT ROTATION speed 5
245 – 247			LEFT ROTATION speed 6
248 – 250			LEFT ROTATION speed 7
251 – 253			LEFT ROTATION speed 8
254 – 255			LEFT ROTATION speed 9 MAX
DMX CHANNEL		8	PARAMETER: BEAM SHAPE / FROST
DMX RANGE VALUE	MID POINT DMX VALUE	MOVE RANGE (DEGREES)	FUNCTION
0 – 19			NO EFFECT
20 – 39			FROST
40 – 255			BEAM SHAPE
DMX CHANNEL		9	PARAMETER: ZOOM
DMX RANGE VALUE	MID POINT DMX VALUE	MOVE RANGE (DEGREES)	FUNCTION
0 – 255			PROPORTIONAL